

# BODY ELECTRICAL

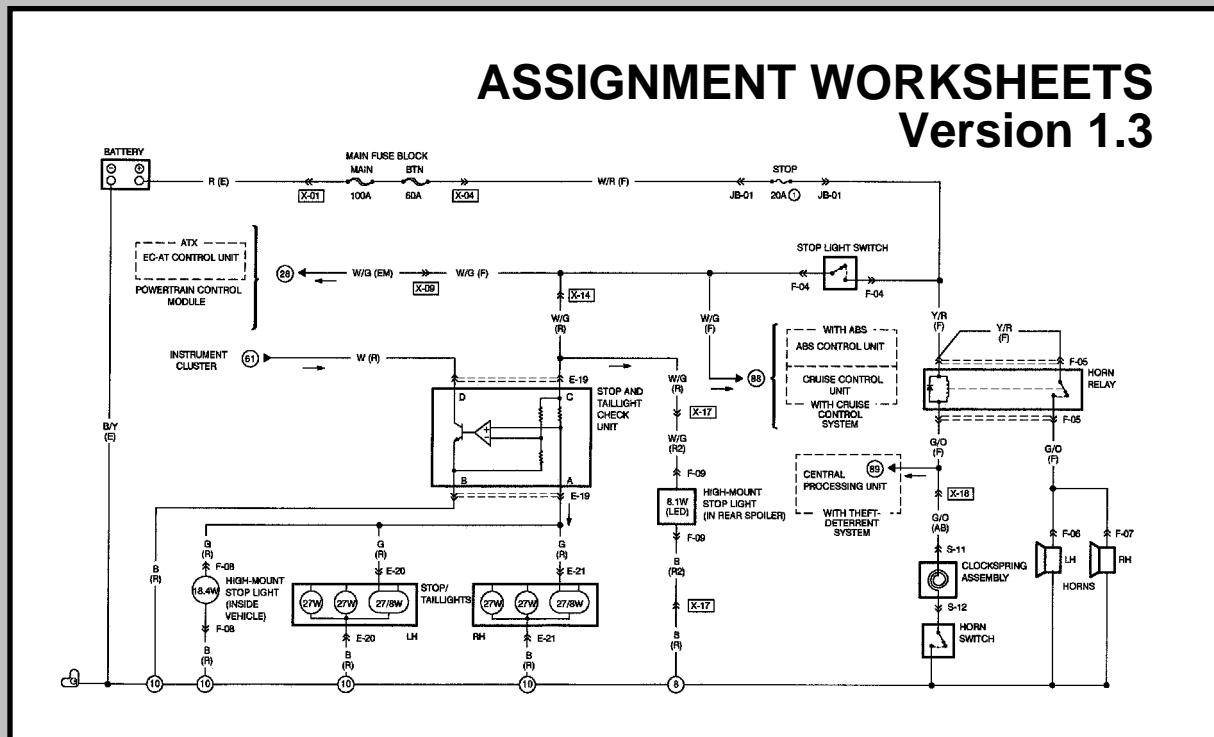

# MAZDA ELECTRICAL WIRING DIAGRAM WORKBOOK

<http://www.autoshop101.com>

*Developed by Kevin R. Sullivan*

*All rights reserved.*

# MAZDA

## Table of Contents

---

### Wiring Diagrams

- 1. Understanding Diagrams Page U-1

### Lighting Systems

- 1. Headlights Page L-1
- 2. Turnsignals & Hazard Page L-2
- 3. Stop Lights Page L-3
- 4. Backup / Horn Page L-4

### Accessories Systems

- 1. Power Windows Page A-1
- 2. Power Mirrors Page A-2
- 3. Door Locks Page A-3
- 4. Clock & Cig Lighter Page A-4
- 5. Front Wiper & Washer Page A-5
- 6. Blower Page A-6

# MAZDA

## Understanding Wiring Diagrams Worksheets

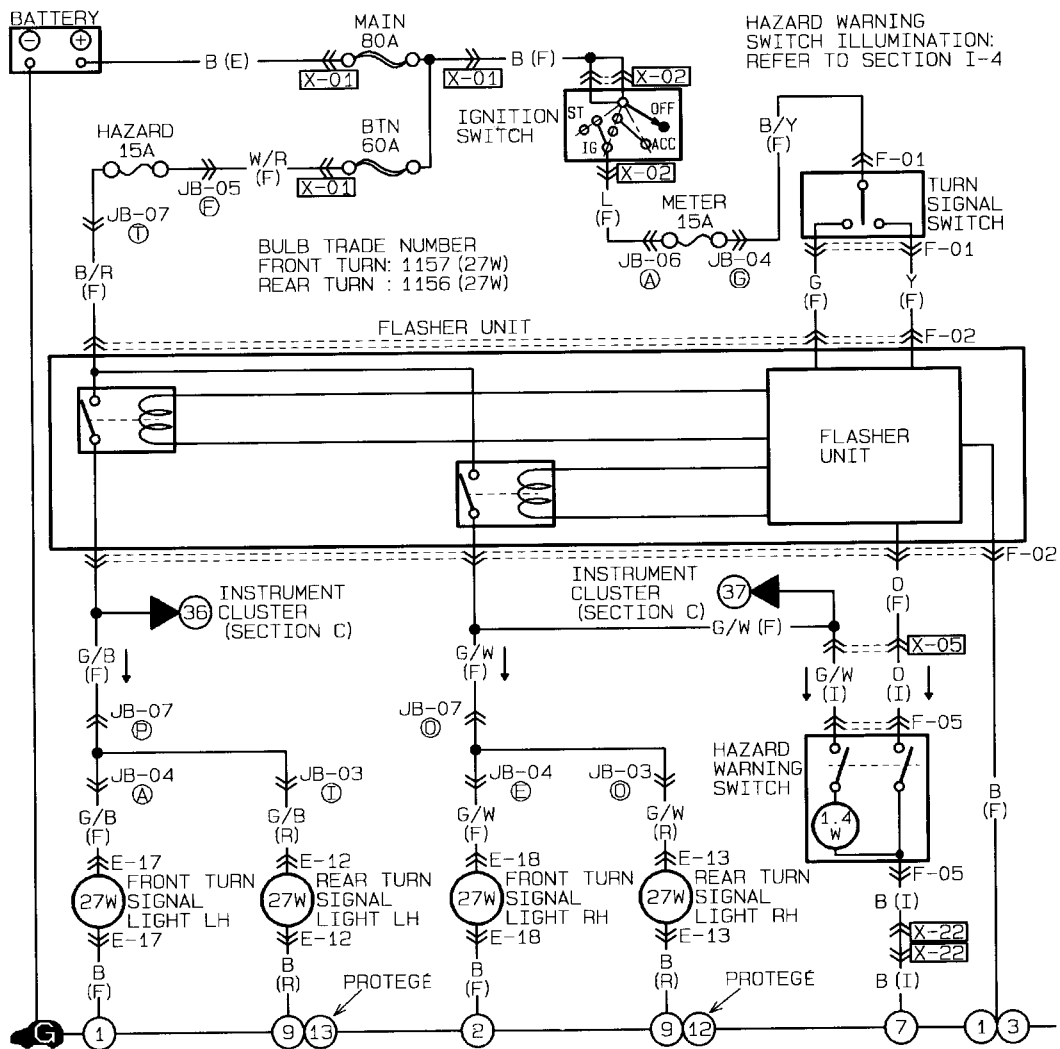

HOW TO USE THIS MANUAL



HOW TO USE THIS MANUAL

OUTLINE

The Body Electrical Troubleshooting Manual is intended as an aid for repairing the body electrical systems of the vehicle.

This manual contains the following important information for use during body electrical diagnosis.

- System operation
- Wiring schematics
- Diagnosis procedure
- Repair procedure



29UGIX-103

FUNDAMENTALS OF TROUBLESHOOTING

Proceed with troubleshooting of the body electrical system by following the steps below.

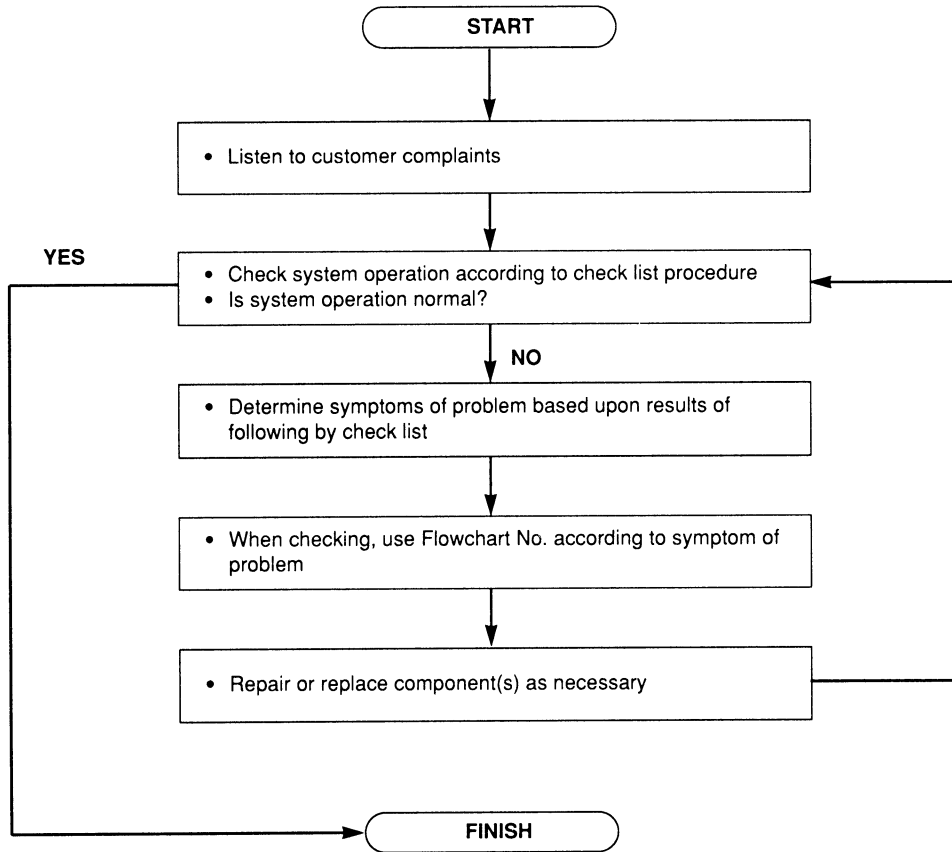

29UGIX-104

# GI

## HOW TO USE THIS MANUAL

### CONTENTS OF MANUAL

This manual comprises the seven groups shown below.

	GI	General Information	A how to on using manual, using test equipment, checking harnesses and connectors, and finding trouble spots
	TI	Troubleshooting Index	Shows symptoms for all systems
	Y	Joint Connector and Ground Points	Shows joint connectors and ground routing from/to battery
	W	Electrical Wiring Schematics	Diagnosis system wiring including fuses and connections
	C~T, Z	Troubleshooting of individual systems	Shows system operation, circuit and connector diagrams, components and connector location, and troubleshooting and repair procedures
	X	Common Connectors	Shows common connectors throughout system
	PI	Parts Index	Gives page number for each component

29UGIX-105

### GROUND POINTS

This section shows the ground points of the harness.

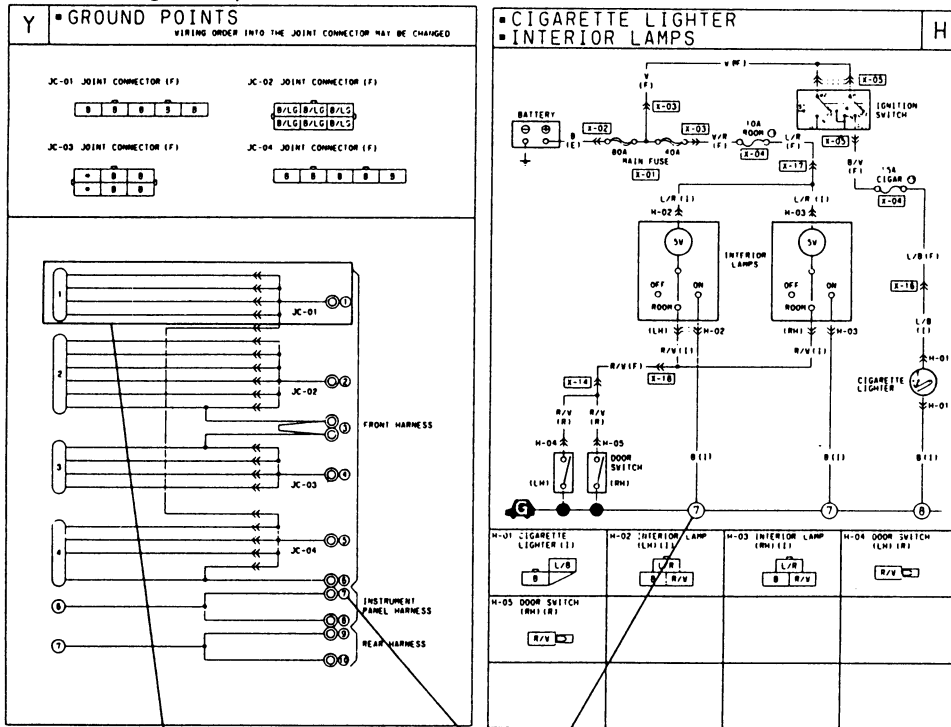

Ground indication	
On vehicle	Indication

**On circuit diagrams and ground points**

The ground connection numbers in system circuit diagrams correspond to those in the ground point diagram.

29UGIX-106

HOW TO USE THIS MANUAL



ELECTRICAL WIRING SCHEMATICS

This shows the power source schematics between the main and/or other fuses of each system. The schematic assists the power source diagnosis if a fuse burns.

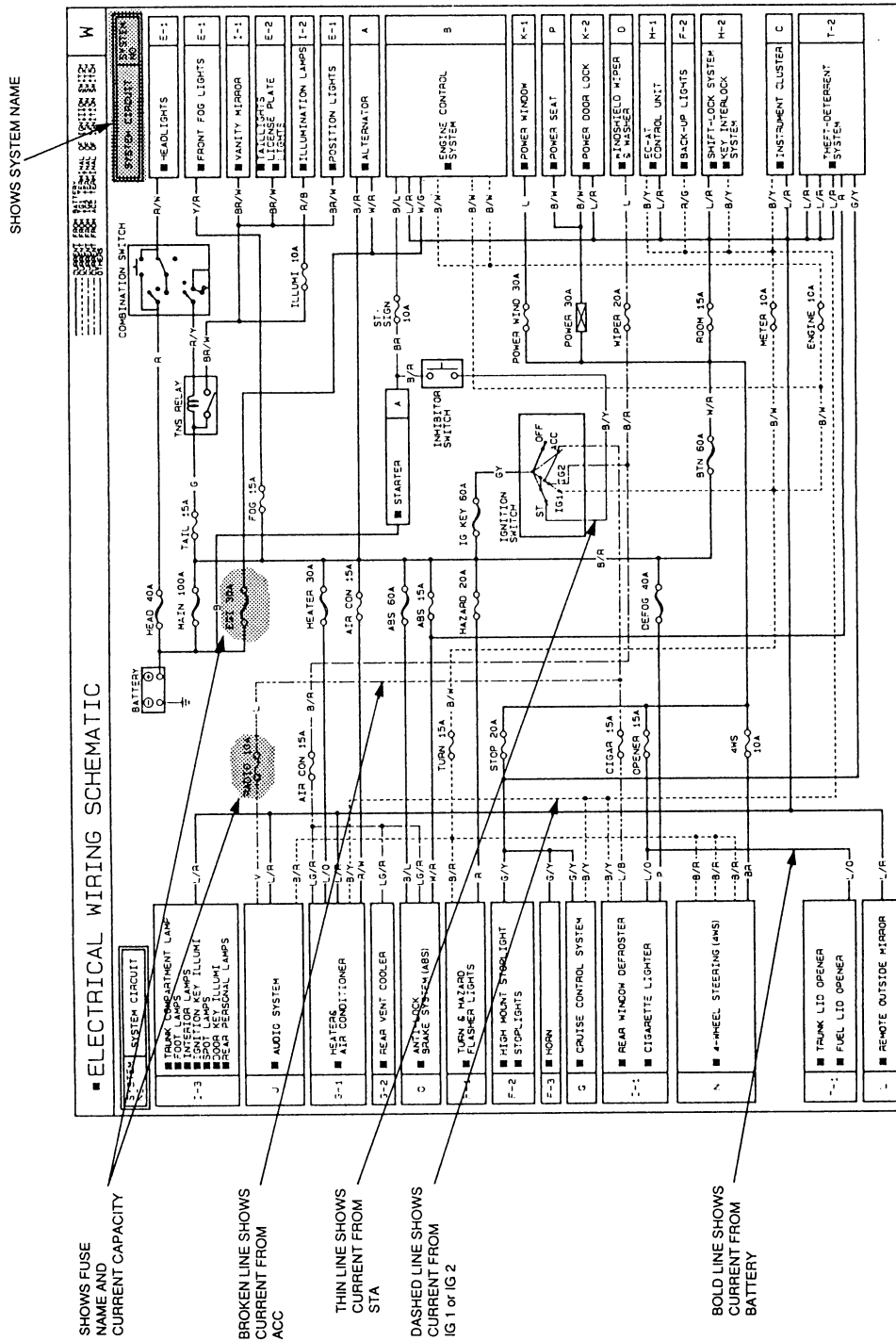

# GI

## HOW TO USE THIS MANUAL

### TROUBLESHOOTING INDEX

This index shows all symptoms and related reference pages for troubleshooting. If troubleshooting is required, the troubleshooting index should be referred to at the beginning of troubleshooting to find the proper procedure.

**System:**  
Systems are distinguished by system name

**Symptom:**  
Choose item that most closely corresponds to actual symptom

TI TROUBLESHOOTING INDEX		
<b>SLIDING SUNROOF</b>		
System	Symptom	Page
Sliding sunroof	Sliding sunroof does not move	M-8
	Slide movement is not possible (tilt movement possible)	M-10
<b>CRUISE CONTROL SYSTEM</b>		
System	Symptom	Page
Cruise control	Vehicle speed cannot be set (cruise control unit will not hold vehicle speed)	O-10
<b>PASSIVE SHOULDER BELT</b>		
System	Symptom	Page
Passive shoulder belt	Passive shoulder belts do not operate	S-7
	One passive shoulder belt stays at forward or rearward position	S-8
	Passive shoulder belt moves forward when door is opened while vehicle speed is more than approx. 8 km/h (4.9 mph)	S-10
	Passive shoulder belt motor does not stop when belt reaches forward most position or rearward position	S-10

**Page:**  
Shows page for troubleshooting procedure

290UGIX-108

### Relationship to "Troubleshooting of Individual System"

Referenced page in troubleshooting index shows the repair procedure for troubleshooting.

TI TROUBLESHOOTING INDEX		
<b>SLIDING SUNROOF</b>		
System	Symptom	Page
Sliding sunroof	Sliding sunroof does not move	M-8
	Slide movement is not possible (tilt movement possible)	M-10

**M SLIDING SUNROOF**

**Check List**

Procedure / Paper operation	Symptom	Flowchart No.
1 Operate sliding sunroof switch and verify that sunroof completely tilts and slide movement	Sliding sunroof does not move	1
	Slide movement is not possible (tilt movement is possible)	2

17F108 22

Flowchart No.1	Symptom
	Sliding sunroof does not move

Possible cause

- SUNROOF fuse burnt
- Damaged sliding sunroof switch
- Damaged sliding sunroof relay
- Damaged sliding sunroof motor
- Open circuit in wiring harness
- Poor connection of connector

17F108 23

**Step 1**  
Check SUNROOF 15A fuse in the fuse block.

Fuse	Action
OK	Go to Step 2
Burnt	Replace fuse after checking and repairing wiring harness

17F108 24

**Step 2**

1 Turn the ignition switch ON.

2 Measure voltage at terminal wire (Q/O) of the sliding sunroof switch harness connector.

V: Battery voltage

Voltage	Action
V <sub>b</sub>	Go to Step 3
Others	Repair wiring harness (Fuse block/Sliding sunroof switch)

17F108 25

**Step 3**  
Disconnect the sliding sunroof switch harness connector, and check for continuity between the terminal wire (B) and a ground.

Continuity	Action
Yes	Go to Step 4
No	Repair wiring harness (Sliding sunroof switch-Ground)

17F108 26

290UGIX-109

HOW TO USE THIS MANUAL

GI

TROUBLESHOOTING OF INDIVIDUAL SYSTEM

These sections contain system operation, system circuit and connector diagrams, component and connector locations, and troubleshooting and repair procedures for each system.

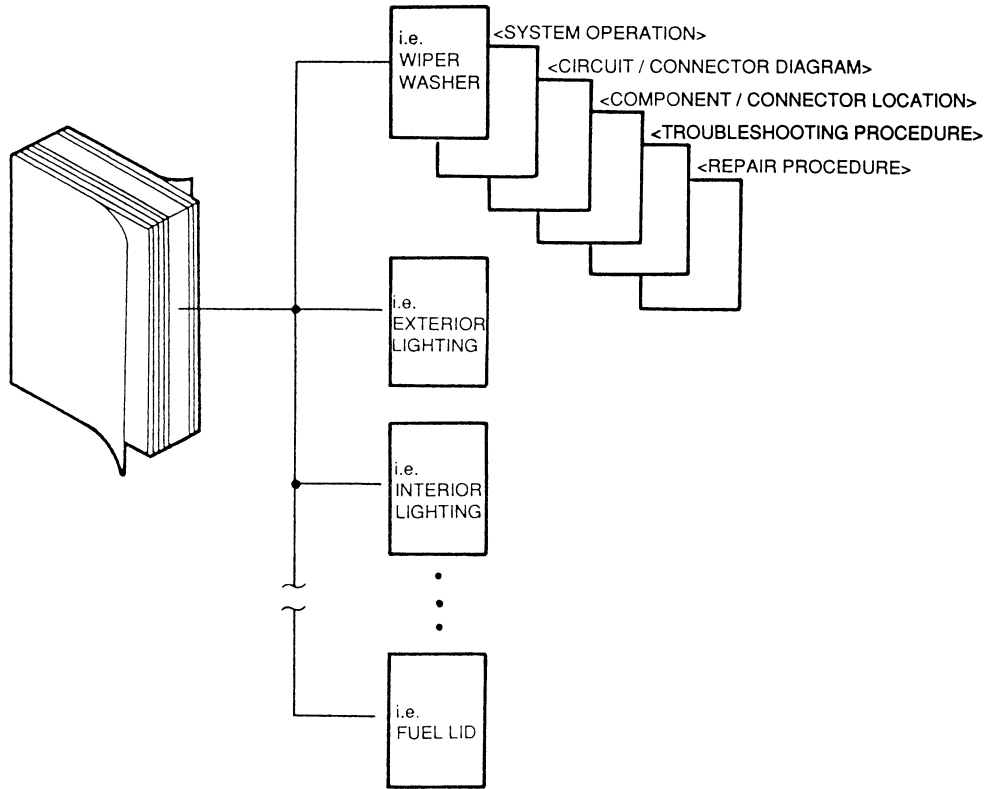

GI

29UGIX-110

SYSTEM OPERATION

System operation shows the current flow and how the system is operated.

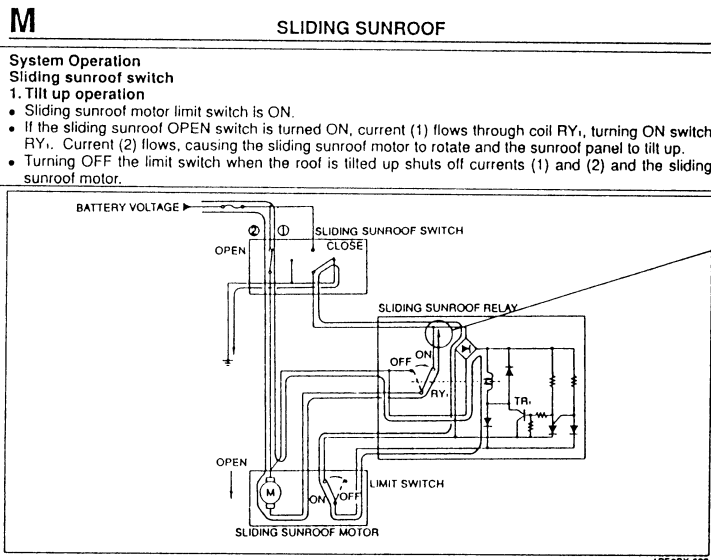

System operation:  
Shows how the system and parts operate

Shows current flow

1PE05X-522

29UGIX-111

# GI

## HOW TO USE THIS MANUAL

### System Circuit Diagram / Connector Diagram

These diagrams show the circuits for each system, from the power supply to the ground. The power supply side is on the upper part of the diagram, the ground side on the lower part. The diagram describes the circuit with the ignition switch OFF.

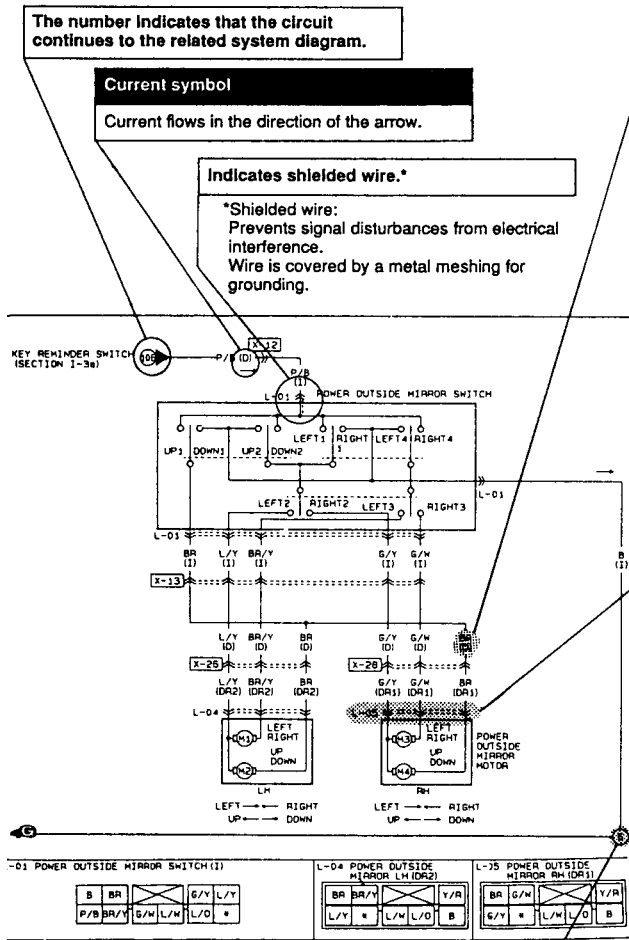

### Wire color code (harness symbol)

- Two-color wires are indicated by a two-letter symbol. The first indicates the base color of the wire, the second the color of the stripe. For example:  
W/R is a white wire with a red strip  
BR/Y is a brown wire with a yellow strip

Symbol (Example)

Solid color wire	Striped wire
B (F) Black	W/R (F) White (base color) with Red (stripe)

- The harness symbol is in ( ) following the harness symbols (refer to GI-7.).

### Connector symbols

- Male and female connectors are represented as follows in the circuit and connector diagrams.

	Circuit diagram symbol	Connector diagram symbol
Male		
Female		

- Like connectors are linked by dashed lines between the connector symbols.
- Connector diagrams show connectors on the harness side. The terminal indicates the view from the harness side.

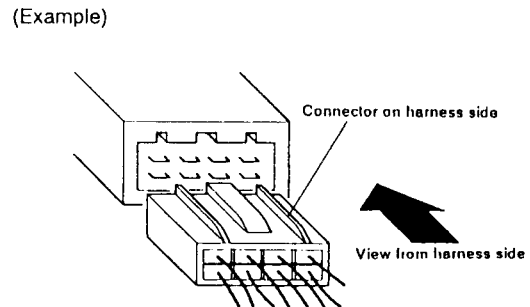

- Colors for connectors except milk-white are given in locations.
- Unused terminals are indicated by \*.

### Ground numbers

A harness ground is represented differently than a unit ground.

Types of grounds	Symbol
<b>Harness</b> 	
<b>Unit</b> 	

**Sensor**

HOW TO USE THIS MANUAL

GI

Component Location / Connector Location

These location illustrations show where electrical components and connectors are on the system circuit diagram by call out lines and connector symbols.

Component name

Shows the names of components in routing diagrams.

GI

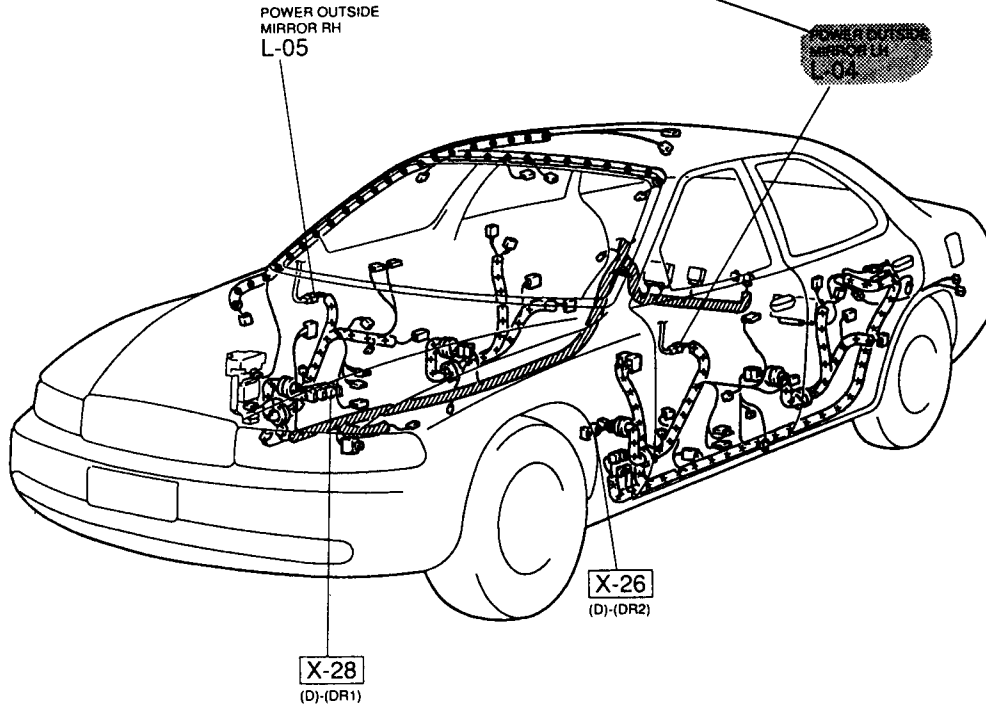

29UGIX-113

Ground symbol

Shows the ground in system diagrams.

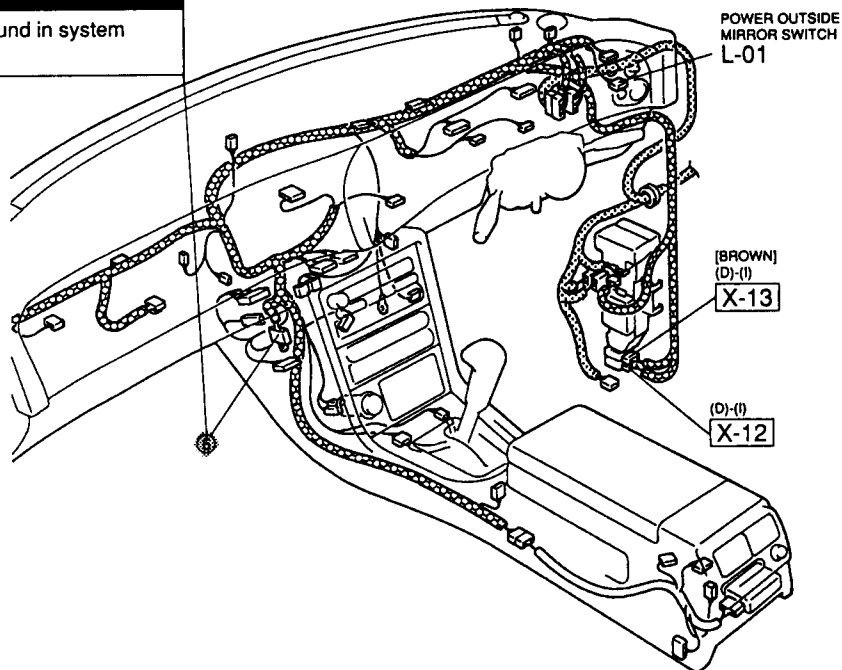

# GI

## HOW TO USE THIS MANUAL

### Troubleshooting Procedure

This procedure shows how to troubleshoot the problem and inspect the part as described by illustrations and text.

**M SLIDING SUNROOF**

**Check List**

Procedure / Paper operation	Symptom	Flowchart No.
1 Operate sliding sunroof switch and verify that sunroof completes tilt and slide movement	Sliding sunroof does not move	1
	Slide movement is not possible (tilt movement is possible)	2

*IPESB4-232*

**Flowchart No.1** Symptom: Sliding sunroof does not move at all

**SUNROOF 15A FUSE**

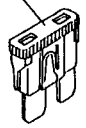

*IPESB4-233*

**Step 1**  
Check SUNROOF 15A fuse in the fuse block.

Fuse	Action
OK	Go to Step 2
Burnt	Replace fuse after checking and repairing wiring harness

**Step 2**

- Turn the ignition switch ON.
- Measure voltage at terminal wire (G/O) of the sliding sunroof switch harness connector.

Vs: Battery voltage

Voltage	Action
Vs	Go to Step 3
Others	Repair wiring harness (Fuse block-Sliding sunroof switch)

*IPESB4-235*

**Illustration:**  
Shows the part location and how to inspect the part

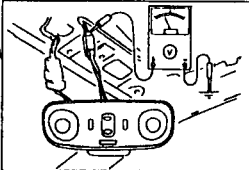

*IPESB4-235*

**Describes trouble-shooting procedure including specifications**

29UGIX-114

### Repair Procedure

This procedure shows how to remove and install a part.

Expendable parts, tightening torques, and symbols for the use of oil, grease, and sealant are shown in the overview illustration.

**Removal / Installation**

**REAR DOOR**

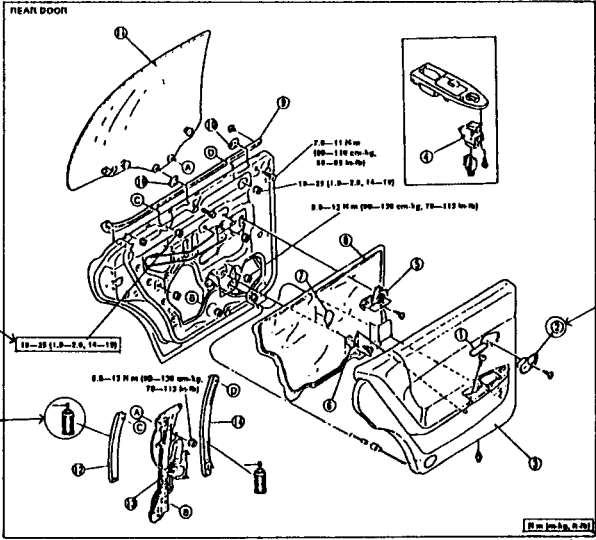

**Tightening torque specifications**

**Application point of oil etc.**

**Numbers refer to parts and servicing procedure**

**Tightening torque unit**

**Removal order**

1. Recess cover	6. Bracket	12. Glass guide B
2. Inner handle cover	7. Sealing pad	13. Window regulator inspection .... page K1-14
3. Rear door trim	8. Door screen	14. Glass guide A
4. Power window sub switch inspection .... page K1-14	9. Rear bellline molding	
5. Inner handle	10. Upper glass stop	
	11. Rear door glass	









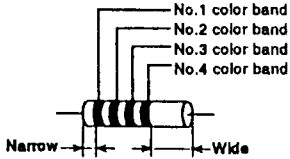
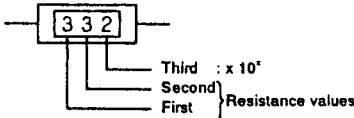
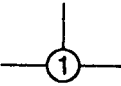

*IPESB4-236*

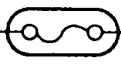
29UGIX-115

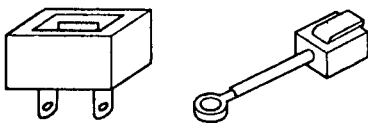
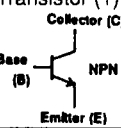
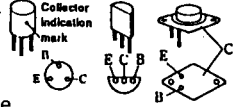
GI

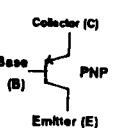
HOW TO USE THIS MANUAL

SYMBOLS











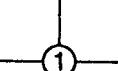
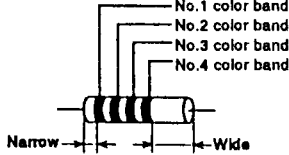

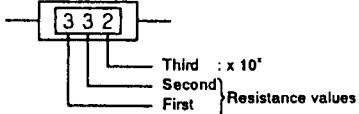
Symbol	Meaning	Symbol	Meaning																																																																											
<p>Battery</p> 	<ul style="list-style-type: none"> <li>Generates electricity through chemical reaction.</li> <li>Supplies direct current to circuits.</li> </ul>	Resistance	<ul style="list-style-type: none"> <li>A resistor with a constant value.</li> <li>Mainly used to protect electrical components in circuits by maintaining rated voltage.</li> </ul> <p>• Reading resistance values.</p> <p>&lt;Colored&gt;</p>  <table border="1" data-bbox="987 760 1360 1165"> <thead> <tr> <th></th> <th>No.1</th> <th>No.2</th> <th>No.3</th> <th>No.4</th> </tr> <tr> <th>Color</th> <th>Resistance values</th> <th>Multiplier</th> <th colspan="2">Tolerance</th> </tr> </thead> <tbody> <tr><td>Black</td><td>0</td><td>0</td><td>x10<sup>0</sup></td><td></td></tr> <tr><td>Brown</td><td>1</td><td>1</td><td>x10<sup>1</sup></td><td></td></tr> <tr><td>Red</td><td>2</td><td>2</td><td>x10<sup>2</sup></td><td></td></tr> <tr><td>Orange</td><td>3</td><td>3</td><td>x10<sup>3</sup></td><td></td></tr> <tr><td>Yellow</td><td>4</td><td>4</td><td>x10<sup>4</sup></td><td></td></tr> <tr><td>Green</td><td>5</td><td>5</td><td>x10<sup>5</sup></td><td></td></tr> <tr><td>Blue</td><td>6</td><td>6</td><td>x10<sup>6</sup></td><td></td></tr> <tr><td>Purple</td><td>7</td><td>7</td><td>x10<sup>7</sup></td><td></td></tr> <tr><td>Grey</td><td>8</td><td>8</td><td>x10<sup>8</sup></td><td></td></tr> <tr><td>White</td><td>9</td><td>9</td><td>x10<sup>9</sup></td><td></td></tr> <tr><td>Gold</td><td></td><td></td><td>x10<sup>-1</sup></td><td>± 5%</td></tr> <tr><td>Silver</td><td></td><td></td><td>x10<sup>-2</sup></td><td>± 10%</td></tr> <tr><td>-</td><td></td><td></td><td></td><td>+20%</td></tr> </tbody> </table> <p>&lt;Numerical&gt;</p> 		No.1	No.2	No.3	No.4	Color	Resistance values	Multiplier	Tolerance		Black	0	0	x10 <sup>0</sup>		Brown	1	1	x10 <sup>1</sup>		Red	2	2	x10 <sup>2</sup>		Orange	3	3	x10 <sup>3</sup>		Yellow	4	4	x10 <sup>4</sup>		Green	5	5	x10 <sup>5</sup>		Blue	6	6	x10 <sup>6</sup>		Purple	7	7	x10 <sup>7</sup>		Grey	8	8	x10 <sup>8</sup>		White	9	9	x10 <sup>9</sup>		Gold			x10 <sup>-1</sup>	± 5%	Silver			x10 <sup>-2</sup>	± 10%	-				+20%
	No.1	No.2	No.3	No.4																																																																										
Color	Resistance values	Multiplier	Tolerance																																																																											
Black	0	0	x10 <sup>0</sup>																																																																											
Brown	1	1	x10 <sup>1</sup>																																																																											
Red	2	2	x10 <sup>2</sup>																																																																											
Orange	3	3	x10 <sup>3</sup>																																																																											
Yellow	4	4	x10 <sup>4</sup>																																																																											
Green	5	5	x10 <sup>5</sup>																																																																											
Blue	6	6	x10 <sup>6</sup>																																																																											
Purple	7	7	x10 <sup>7</sup>																																																																											
Grey	8	8	x10 <sup>8</sup>																																																																											
White	9	9	x10 <sup>9</sup>																																																																											
Gold			x10 <sup>-1</sup>	± 5%																																																																										
Silver			x10 <sup>-2</sup>	± 10%																																																																										
-				+20%																																																																										
<p>Ground (1)</p> 	<ul style="list-style-type: none"> <li>Connecting point to vehicle body or other ground wire where current flows from positive to negative terminal of battery.</li> <li>Ground (1) indicates a ground point to body through wire harness.</li> </ul>																																																																													
<p>Ground (2)</p> 	<ul style="list-style-type: none"> <li>Ground (2) indicates point where component is grounded directly to body.</li> </ul> <p>Remarks</p> <ul style="list-style-type: none"> <li>Current will not flow through a circuit if ground is faulty.</li> </ul>																																																																													
<p>Fuse (1)</p>  <p>(blade)</p>	<ul style="list-style-type: none"> <li>Melts when current flow exceeds that specified for circuit; stopping current flow.</li> </ul> <p>Precautions</p> <ul style="list-style-type: none"> <li>Do not replace with fuses exceeding specified capacity.</li> </ul>																																																																													
<p>Fuse (2)</p>  <p>(cartridge)</p>	<p>&lt;Blade type&gt;      &lt;Cartridge type&gt;</p> 																																																																													
<p>Main fuse/ Fusible link</p> 	<p>&lt;Main fuse&gt;      &lt;Fusible link&gt;</p> 																																																																													
<p>Transistor (1)</p> 	<ul style="list-style-type: none"> <li>Electrical switching component.</li> <li>Turns on when voltage is applied to the base (B).</li> </ul> 	<p>Motor</p> 	<ul style="list-style-type: none"> <li>Converts electrical energy into mechanical energy.</li> </ul>																																																																											
<p>Transistor (2)</p> 	<p>• Reading code</p> <p>2 S C 828 A      Revision mark</p> <p>Semiconductor      A:High-frequency PNP B:Low-frequency PNP C:High-frequency NPN D:Low-frequency NPN</p> <p>Number of terminals</p>	<p>Pump</p> 	<ul style="list-style-type: none"> <li>Pulls in and expels gases and liquids.</li> </ul>																																																																											
<p>Lamp</p> 	<ul style="list-style-type: none"> <li>Emits light and generates heat when current flows through filament.</li> </ul>	<p>Cigarette lighter</p> 	<ul style="list-style-type: none"> <li>Electrical coil that generates heat.</li> </ul>																																																																											

01E0TX-016

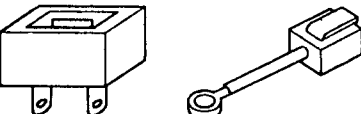
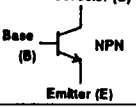
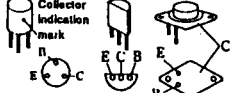
GI

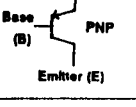
HOW TO USE THIS MANUAL

SYMBOLS

Symbol	Meaning	Symbol	Meaning																																																																												
	<ul style="list-style-type: none"> <li>Generates electricity through chemical reaction.</li> <li>Supplies direct current to circuits.</li> </ul>	Resistance	<ul style="list-style-type: none"> <li>A resistor with a constant value.</li> <li>Mainly used to protect electrical components in circuits by maintaining rated voltage.</li> </ul>																																																																												
	<ul style="list-style-type: none"> <li>Connecting point to vehicle body or other ground wire where current flows from positive to negative terminal of battery.</li> <li>Ground (1) indicates a ground point to body through wire harness.</li> </ul>		<ul style="list-style-type: none"> <li>Reading resistance values.</li> </ul> <p>&lt;Colored&gt;</p>																																																																												
	<ul style="list-style-type: none"> <li>Ground (2) indicates point where component is grounded directly to body.</li> </ul> <p>Remarks</p> <ul style="list-style-type: none"> <li>Current will not flow through a circuit if ground is faulty.</li> </ul>			<table border="1"> <thead> <tr> <th></th> <th>No.1</th> <th>No.2</th> <th>No.3</th> <th>No.4</th> </tr> </thead> <tbody> <tr> <td>Color</td> <td>Resistance values</td> <td>Multiplier</td> <td>Tolerance</td> <td></td> </tr> <tr> <td>Black</td> <td>0</td> <td>0</td> <td>x10<sup>0</sup></td> <td></td> </tr> <tr> <td>Brown</td> <td>1</td> <td>1</td> <td>x10<sup>1</sup></td> <td></td> </tr> <tr> <td>Red</td> <td>2</td> <td>2</td> <td>x10<sup>2</sup></td> <td></td> </tr> <tr> <td>Orange</td> <td>3</td> <td>3</td> <td>x10<sup>3</sup></td> <td></td> </tr> <tr> <td>Yellow</td> <td>4</td> <td>4</td> <td>x10<sup>4</sup></td> <td></td> </tr> <tr> <td>Green</td> <td>5</td> <td>5</td> <td>x10<sup>5</sup></td> <td></td> </tr> <tr> <td>Blue</td> <td>6</td> <td>6</td> <td>x10<sup>6</sup></td> <td></td> </tr> <tr> <td>Purple</td> <td>7</td> <td>7</td> <td>x10<sup>7</sup></td> <td></td> </tr> <tr> <td>Grey</td> <td>8</td> <td>8</td> <td>x10<sup>8</sup></td> <td></td> </tr> <tr> <td>White</td> <td>9</td> <td>9</td> <td>x10<sup>9</sup></td> <td></td> </tr> <tr> <td>Gold</td> <td></td> <td></td> <td>x10<sup>-1</sup></td> <td>± 5%</td> </tr> <tr> <td>Silver</td> <td></td> <td></td> <td>x10<sup>-2</sup></td> <td>± 10%</td> </tr> <tr> <td>-</td> <td></td> <td></td> <td></td> <td>+20%</td> </tr> </tbody> </table>		No.1	No.2	No.3	No.4	Color	Resistance values	Multiplier	Tolerance		Black	0	0	x10 <sup>0</sup>		Brown	1	1	x10 <sup>1</sup>		Red	2	2	x10 <sup>2</sup>		Orange	3	3	x10 <sup>3</sup>		Yellow	4	4	x10 <sup>4</sup>		Green	5	5	x10 <sup>5</sup>		Blue	6	6	x10 <sup>6</sup>		Purple	7	7	x10 <sup>7</sup>		Grey	8	8	x10 <sup>8</sup>		White	9	9	x10 <sup>9</sup>		Gold			x10 <sup>-1</sup>	± 5%	Silver			x10 <sup>-2</sup>	± 10%	-				+20%
	No.1			No.2	No.3	No.4																																																																									
Color	Resistance values	Multiplier	Tolerance																																																																												
Black	0	0	x10 <sup>0</sup>																																																																												
Brown	1	1	x10 <sup>1</sup>																																																																												
Red	2	2	x10 <sup>2</sup>																																																																												
Orange	3	3	x10 <sup>3</sup>																																																																												
Yellow	4	4	x10 <sup>4</sup>																																																																												
Green	5	5	x10 <sup>5</sup>																																																																												
Blue	6	6	x10 <sup>6</sup>																																																																												
Purple	7	7	x10 <sup>7</sup>																																																																												
Grey	8	8	x10 <sup>8</sup>																																																																												
White	9	9	x10 <sup>9</sup>																																																																												
Gold			x10 <sup>-1</sup>	± 5%																																																																											
Silver			x10 <sup>-2</sup>	± 10%																																																																											
-				+20%																																																																											
 <p>(blade)</p>	<ul style="list-style-type: none"> <li>Melts when current flow exceeds that specified for circuit; stopping current flow.</li> </ul> <p>Precautions</p> <ul style="list-style-type: none"> <li>Do not replace with fuses exceeding specified capacity.</li> </ul>	<p>&lt;Numerical&gt;</p> 																																																																													
 <p>(cartridge)</p>	<p>&lt;Blade type&gt;      &lt;Cartridge type&gt;</p> 																																																																														
 <p>Main fuse/ Fusible link</p>	<p>&lt;Main fuse&gt;      &lt;Fusible link&gt;</p> 																																																																														
 <p>Transistor (1) Collector (C) Base (B) NPN Emitter (E)</p>	<ul style="list-style-type: none"> <li>Electrical switching component.</li> <li>Turns on when voltage is applied to the base (B).</li> </ul> 		<ul style="list-style-type: none"> <li>Converts electrical energy into mechanical energy.</li> </ul>																																																																												
 <p>Transistor (2) Collector (C) Base (B) PNP Emitter (E)</p>	<ul style="list-style-type: none"> <li>Reading code</li> </ul> <p>2 S C 828 A</p> <p>Semiconductor      Revision mark</p> <p>Number of terminals      A: High-frequency PNP B: Low-frequency PNP C: High-frequency NPN D: Low-frequency NPN</p>		<ul style="list-style-type: none"> <li>Pulls in and expels gases and liquids.</li> </ul>																																																																												
	<ul style="list-style-type: none"> <li>Emits light and generates heat when current flows through filament.</li> </ul>		<ul style="list-style-type: none"> <li>Electrical coil that generates heat.</li> </ul>																																																																												

01E0TX-016

1. Describe the meaning of the dotted line in the diagram component P.
2. Describe and identify the diagram component Q.
3. Describe and identify the "R/B" in diagram component R.
4. Describe and identify the "F" in diagram component S.
5. Describe and identify the diagram component T.
6. Describe and identify the diagram component U.
7. Describe and identify the diagram component V.
8. Describe and identify the diagram component W.
9. Indicate if the connector attached to the wire is male or female in diagram component X.
10. Describe and identify the diagram component Y.
11. Describe and identify the "F" in diagram component Z..

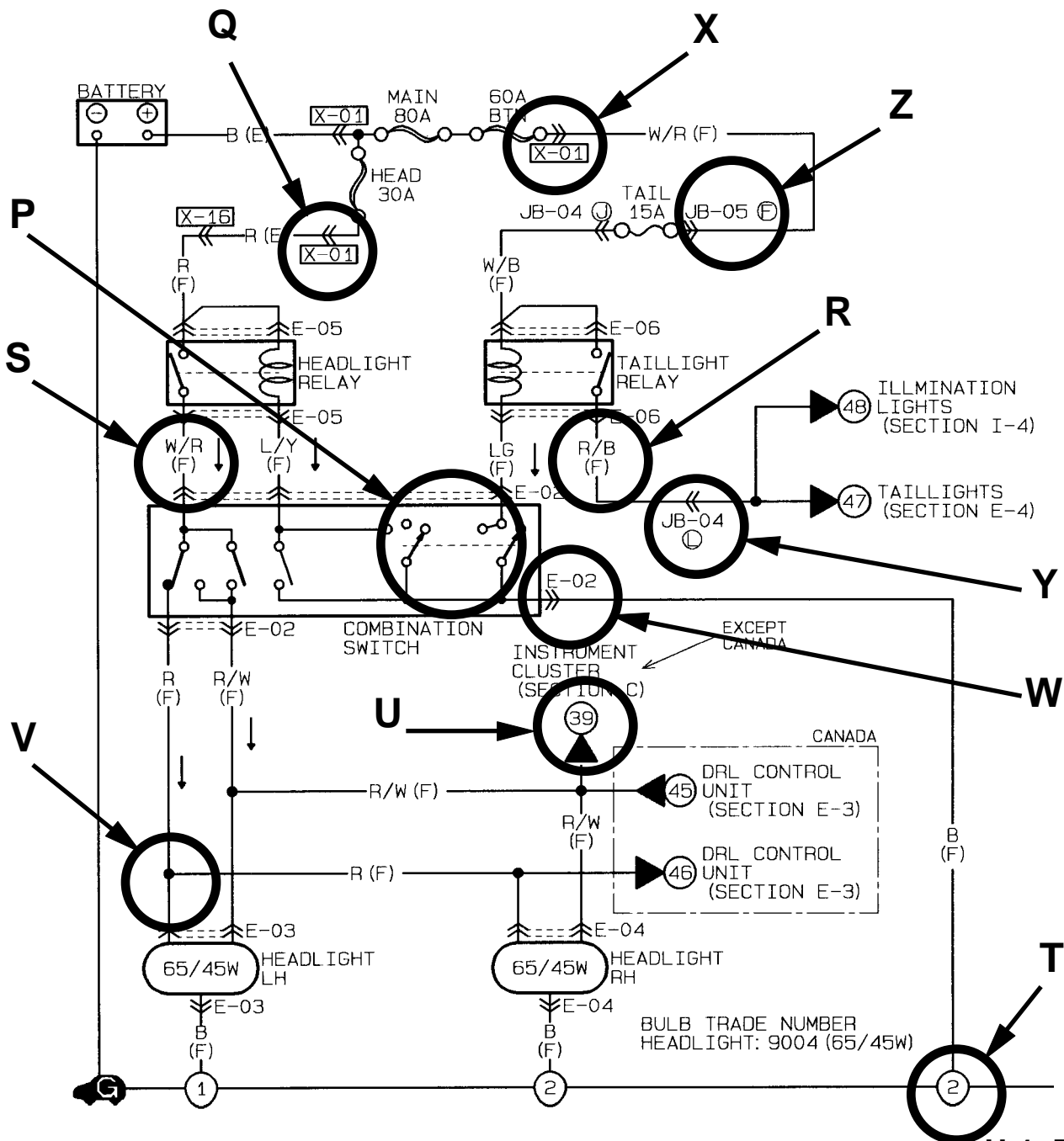

# MAZDA

## Headlamp

## Worksheets

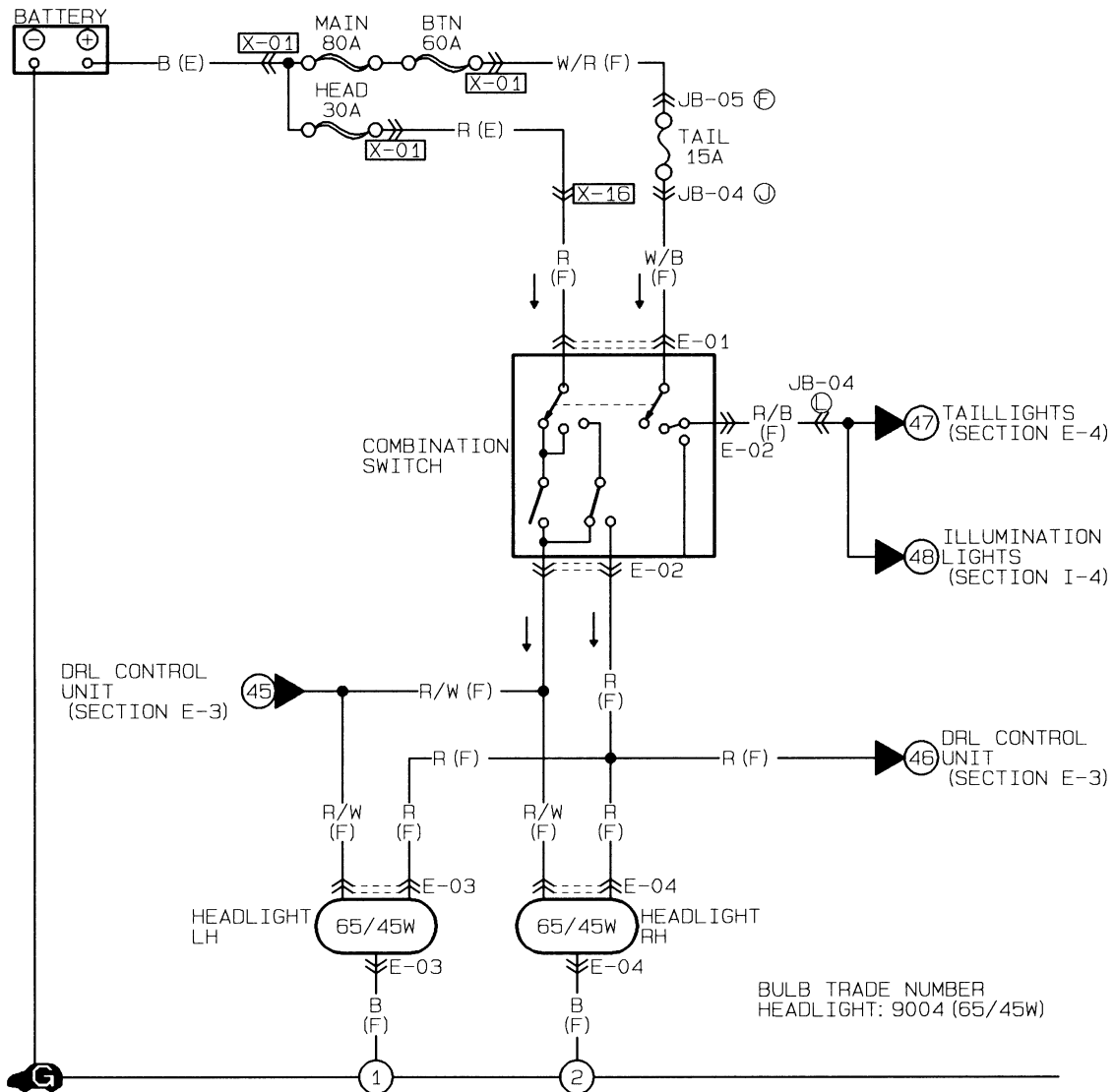

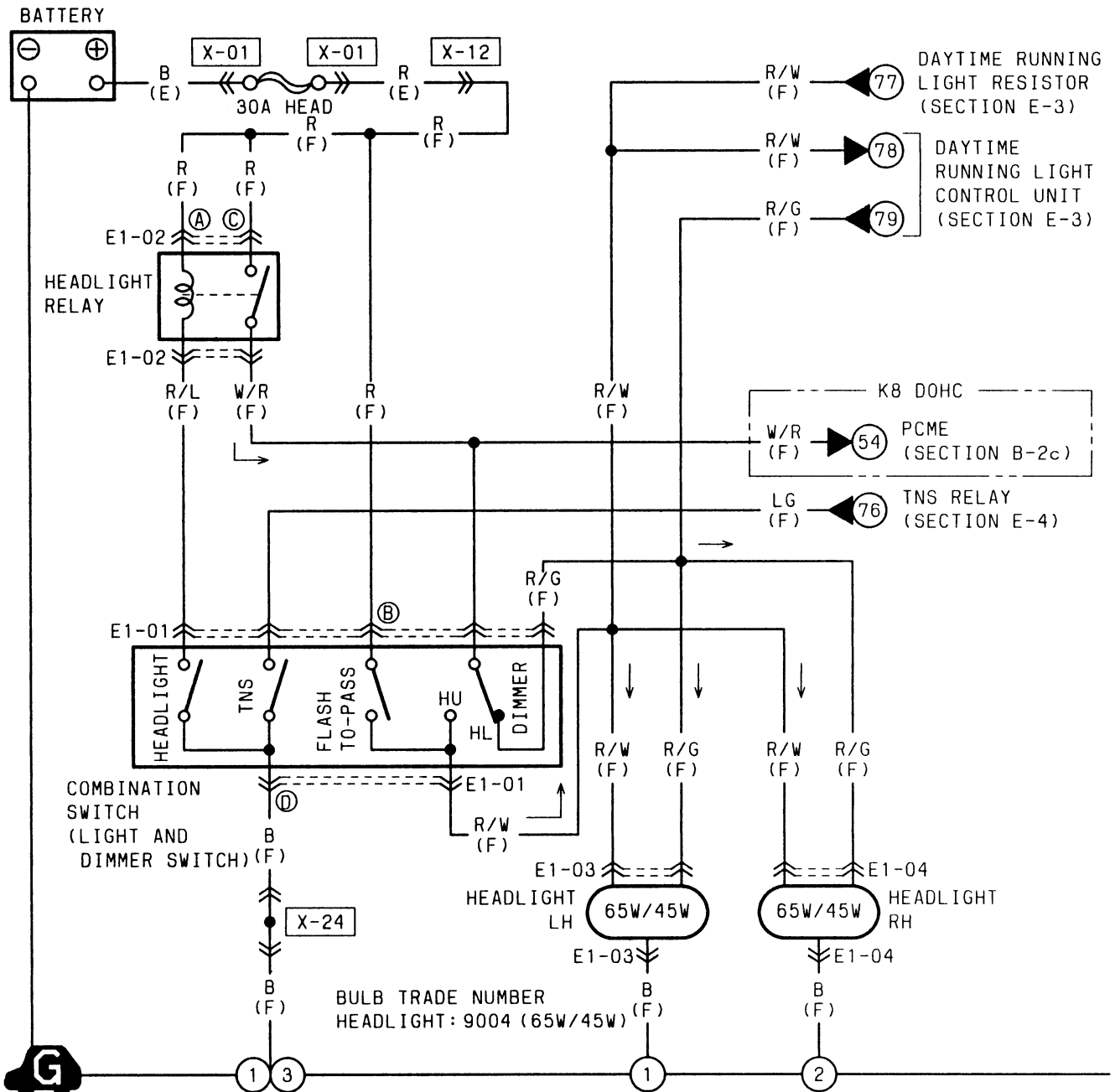

1. Draw in GREEN the HEAD LAMP CONTROL circuit from the battery to ground.
2. Draw in RED the LOW BEAM circuit from the battery to ground.
3. Draw in BLUE the HIGH BEAM circuit from the battery to ground.

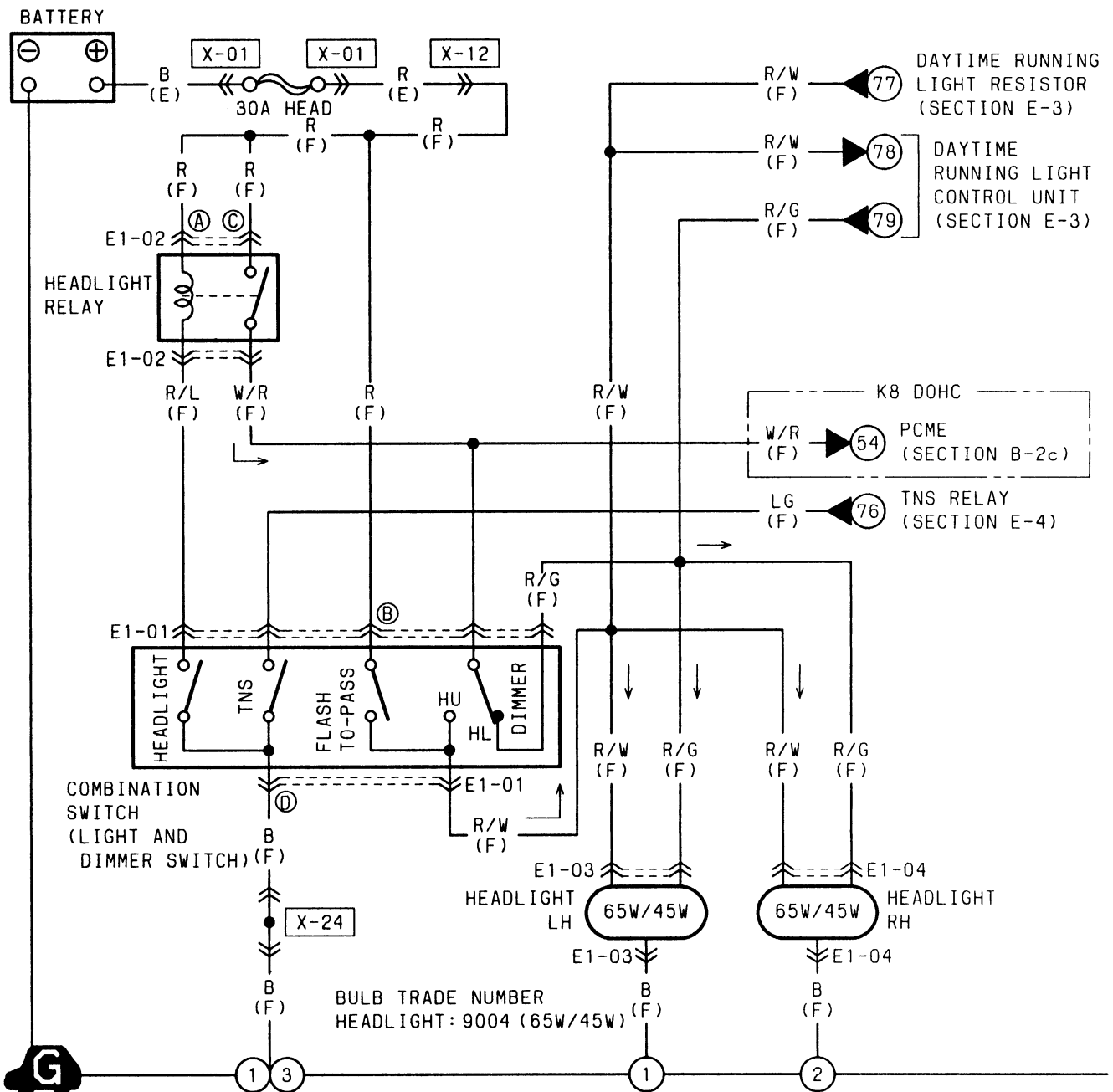

1. Draw in GREEN the HEAD LAMP CONTROL circuit from the battery to ground.
2. Draw in RED the LOW BEAM circuit from the battery to ground.
3. Draw in BLUE the HIGH BEAM circuit from the battery to ground.

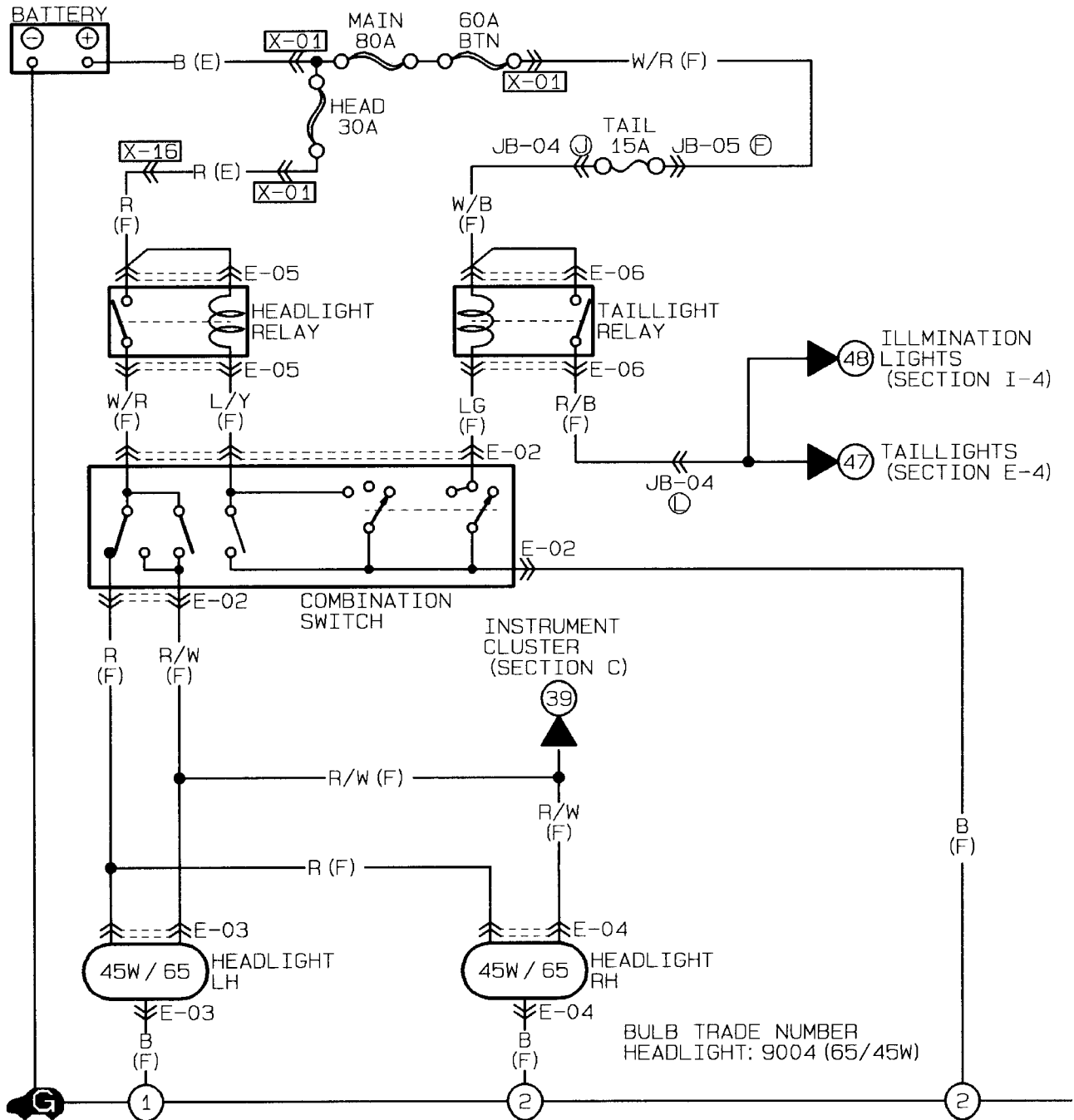

1. With the Headlamp Switch in the OFF position, what voltage would you expect to find at point **V**, **W**, **X**, **Y**, & **Z**.
2. With the Headlamp Switch in the ON position, LOW BEAM position, what voltage would you expect to find at point **V**, **W**, **X**, **Y**, & **Z**.
3. With the Headlamp Switch in the ON position, HIGH BEAM position, what voltage would you expect to find at point **V**, **W**, **X**, **Y**, & **Z**.
4. How will the circuit be affected if there is an open at point **V**.
5. How will the circuit be affected if there is an open at point **W**.
6. How will the circuit be affected if there is an open at point **X**.
7. How will the circuit be affected if there is an open at point **Y**.
8. How will the circuit be affected if there is an open at point **Z**.

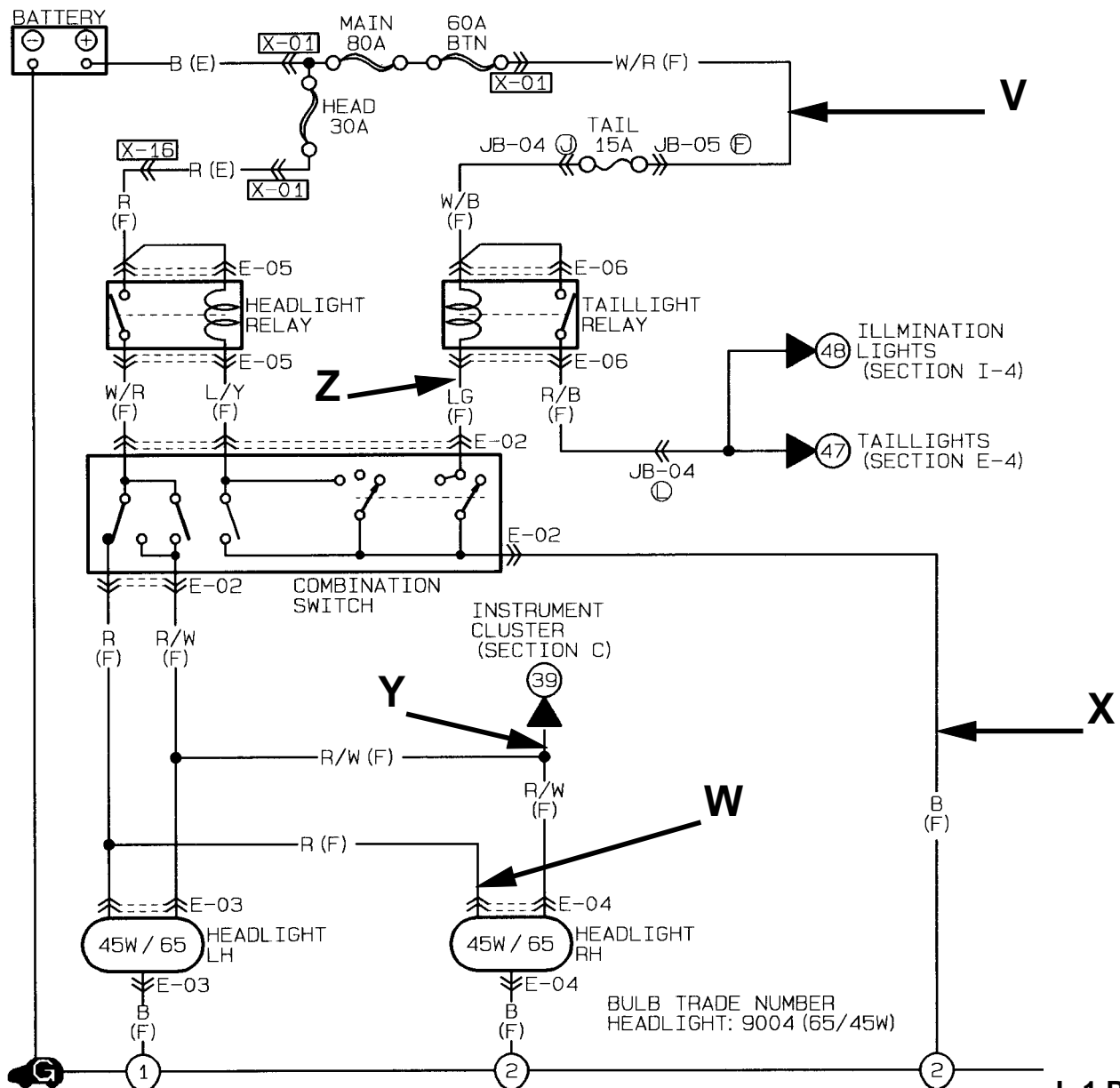

- Trace in GREEN the portion of the circuit below that you suspect could be at fault.  
Both LOW BEAM HEADLAMPS do not work. The lamps work correctly on the High Beam and Flash (passing) positions. The tail lamps function correctly.
- Trace in RED the portion of the circuit below that you suspect could be at fault.  
The LEFT HIGH BEAM HEADLAMP does not work in the High Beam Position. Both lamps function normally in the low beam position. The tail lamps function correctly.
- Trace in BLUE the portion of the circuit below that you suspect could be at fault.  
The LEFT HEADLAMP is DIM in both Low or High Beam Positions. The right lamp functions normally. The tail lamps function correctly.
- Trace in ORANGE the portion of the circuit below that you suspect could be at fault.  
The HEADLAMPS do not work in any position. The tail lamps function correctly.

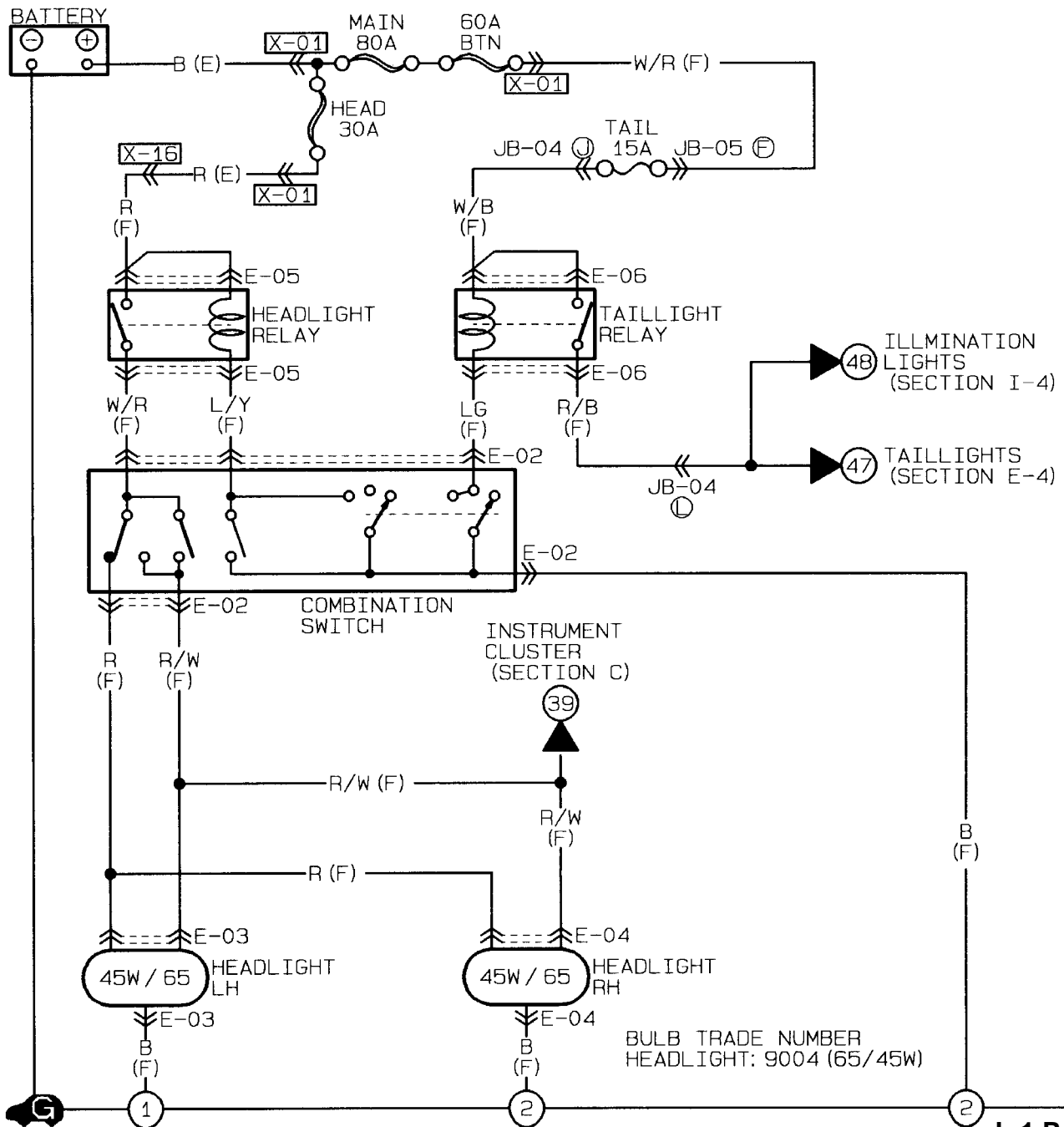

# MAZDA

## Turn/Hazard Lamps Worksheets

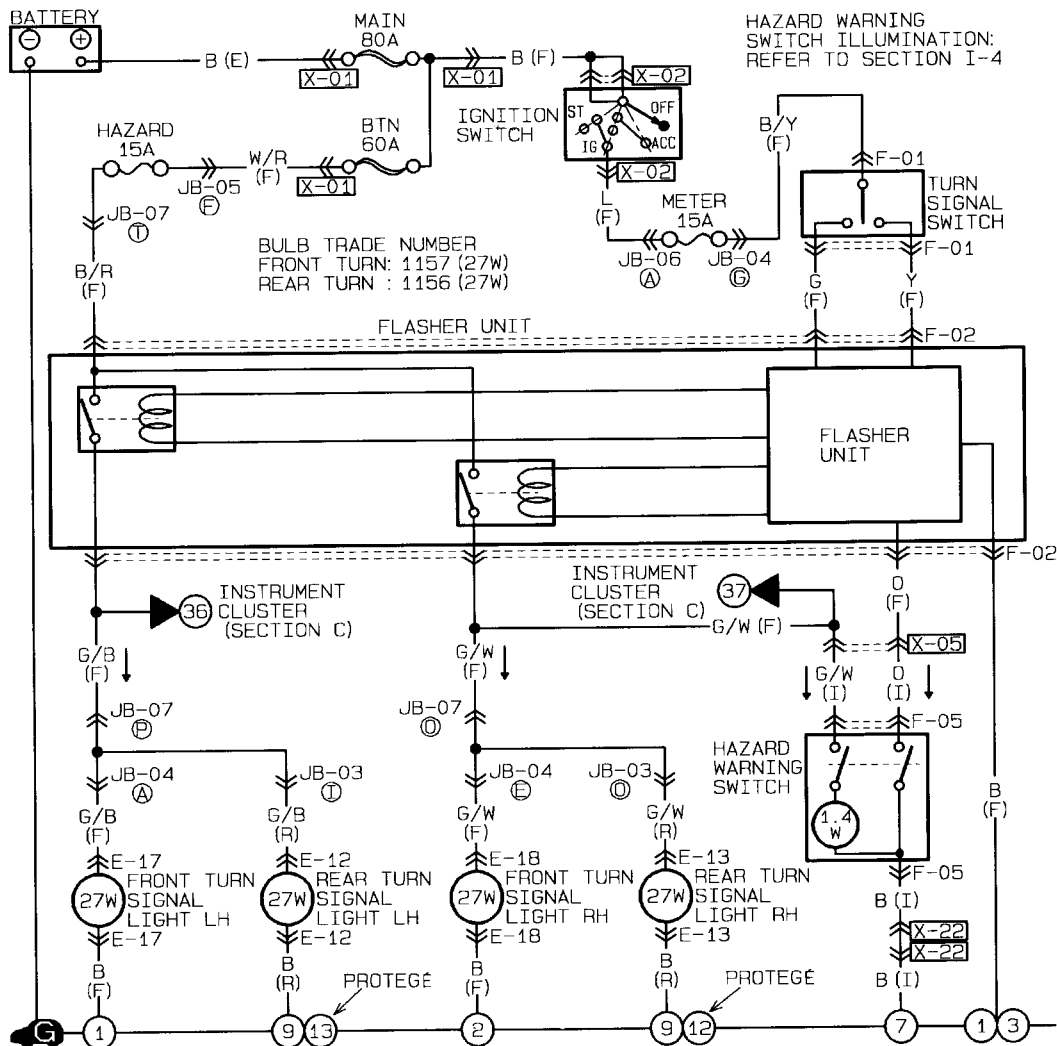

**SYSTEM DIAGRAM**  
Turn and Hazard Warning Light

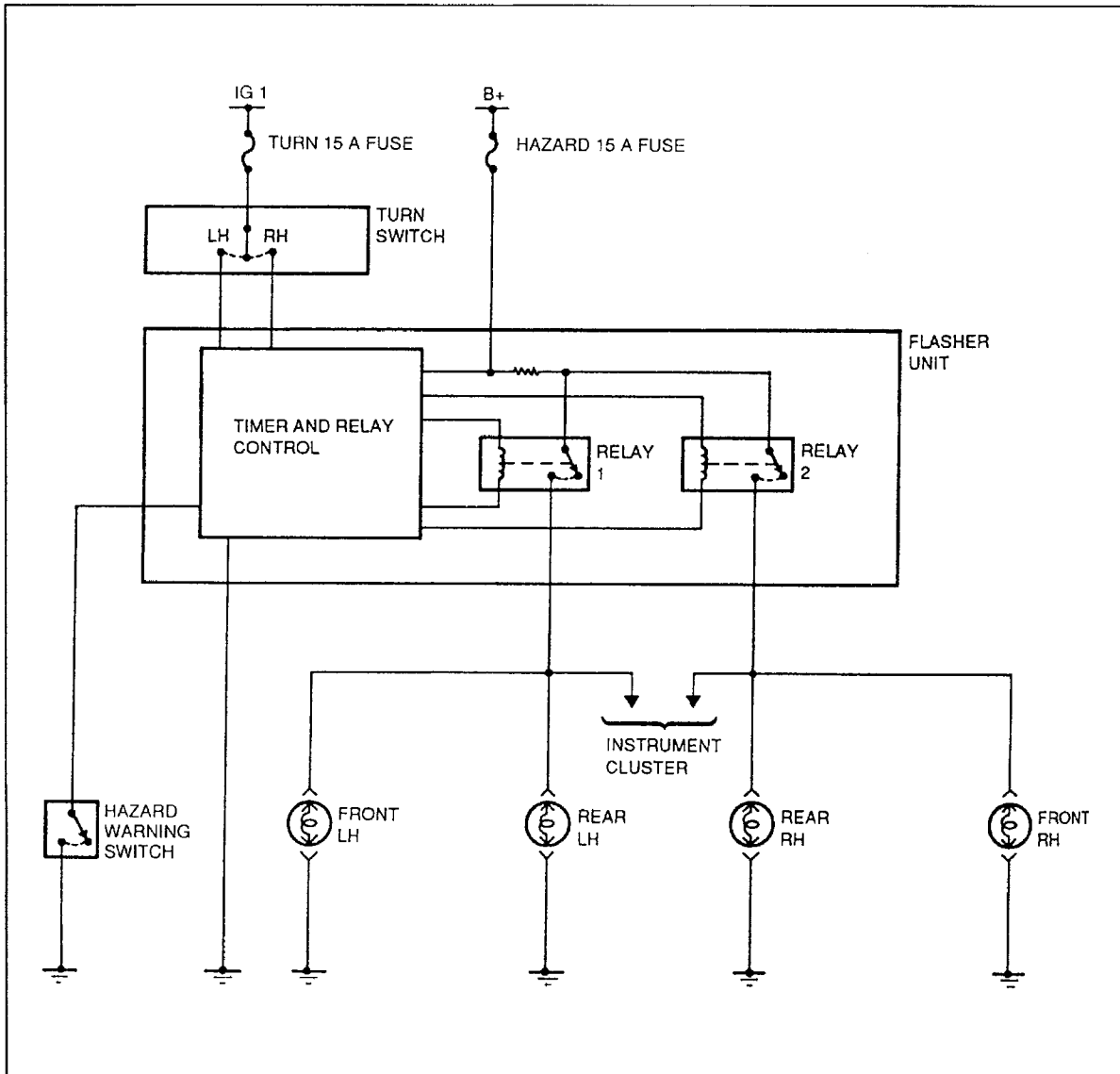

**Description**

The signal lighting system consists of the following components:

- Turn and hazard warning lights in the front combination light
- Turn and hazard warning lights in the rear combination light
- Turn switch in the combination switch
- Hazard warning switch
- Flasher unit

**Operation**

**1. Turn signal lights**

When the turn switch is set to the left (right) position with the ignition switch at ON, relay 1 (relay 2) in the flasher unit closes, turning on the left (right) turn signal lights.

**2. Hazard lights**

When the hazard warning switch is turned on with the ignition switch at any position, relays 1 and 2 in the flasher unit close, turning on the hazard lights.

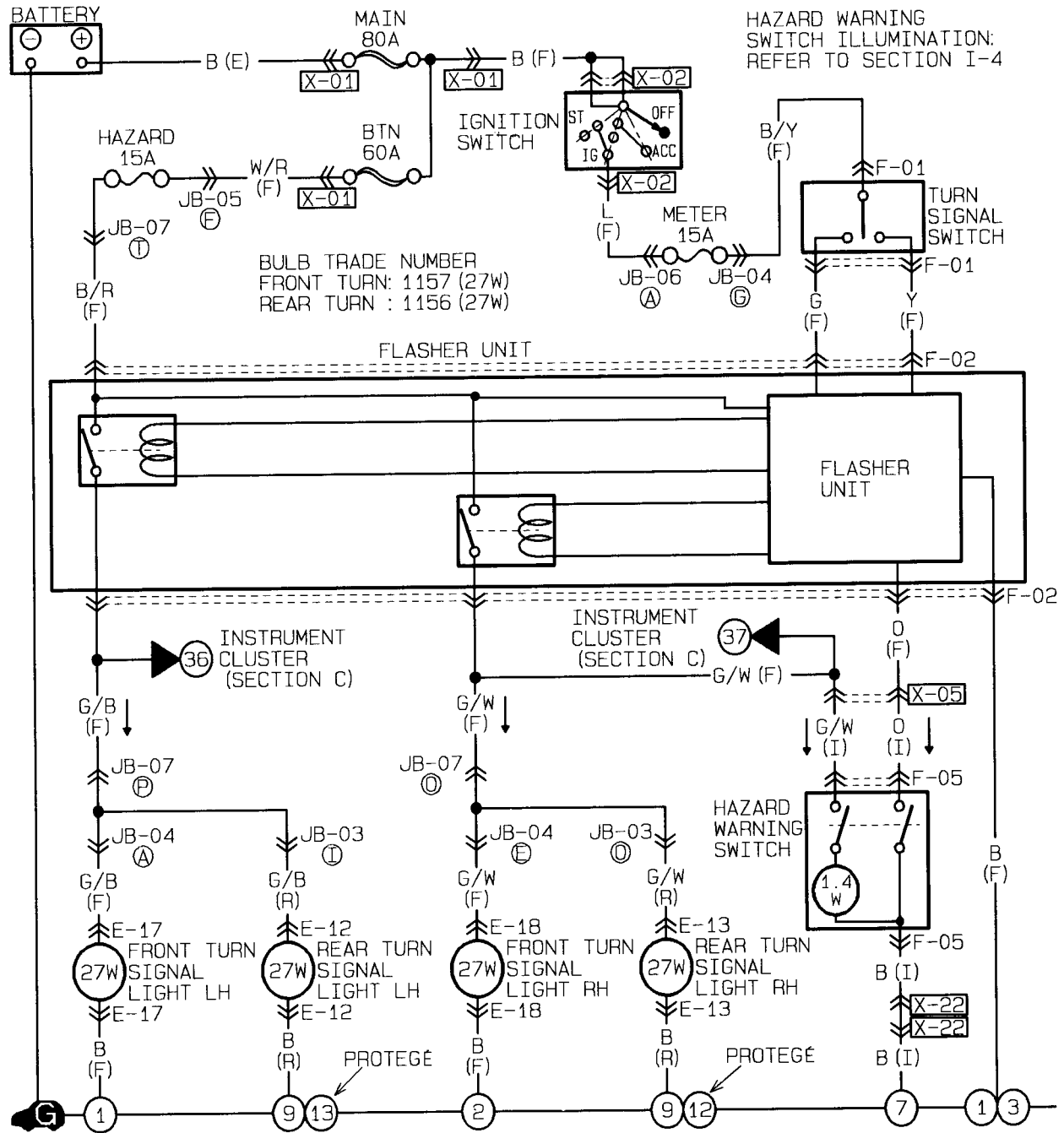

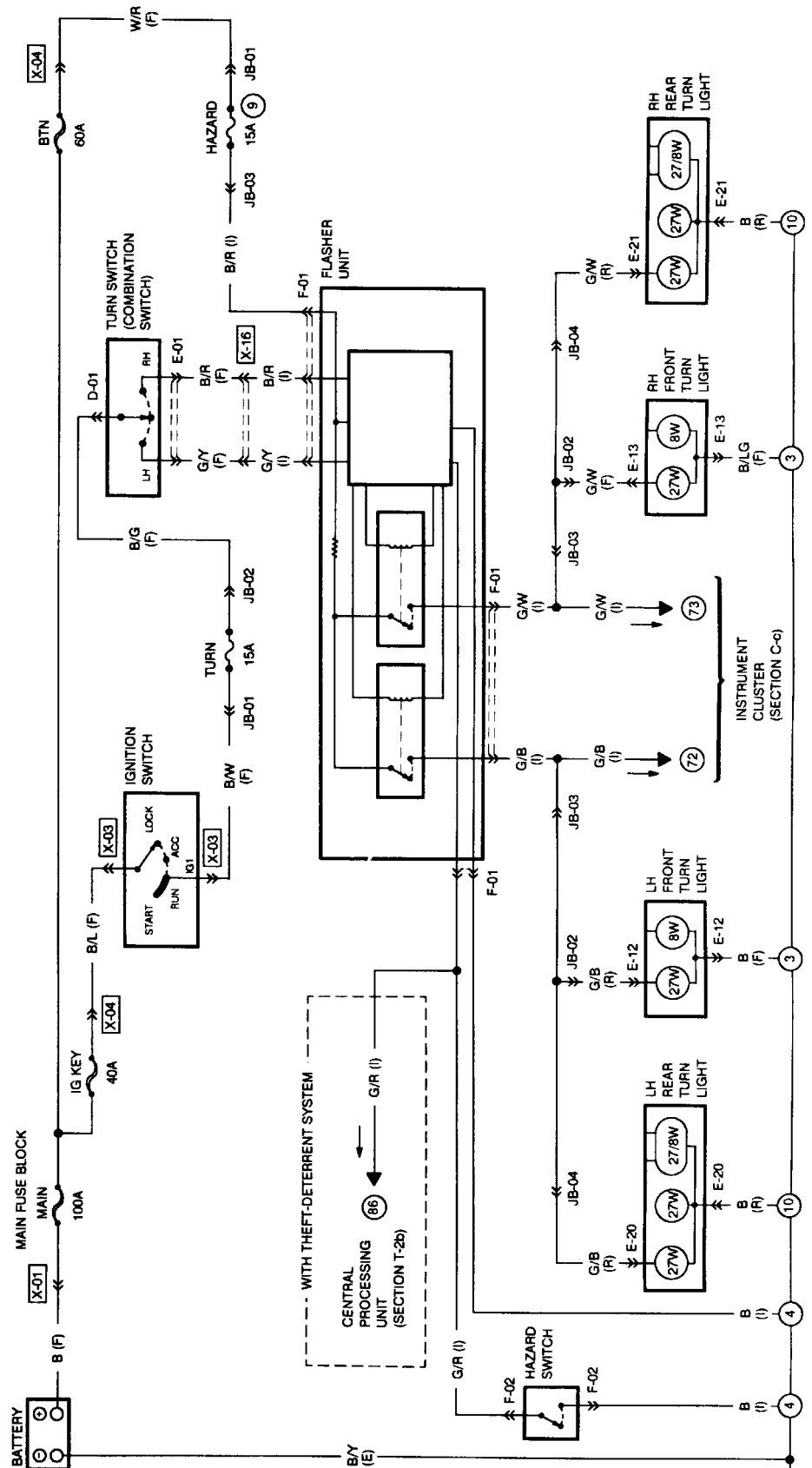

1. Draw in GREEN the RIGHT TURN LAMP INPUT CONTROL circuit from the battery to the flasher.
2. Draw in RED the RIGHT TURN LAMP circuit from the battery to ground.
3. Draw in BLUE the HAZARD INPUT CONTROL circuit from the ground to the flasher.

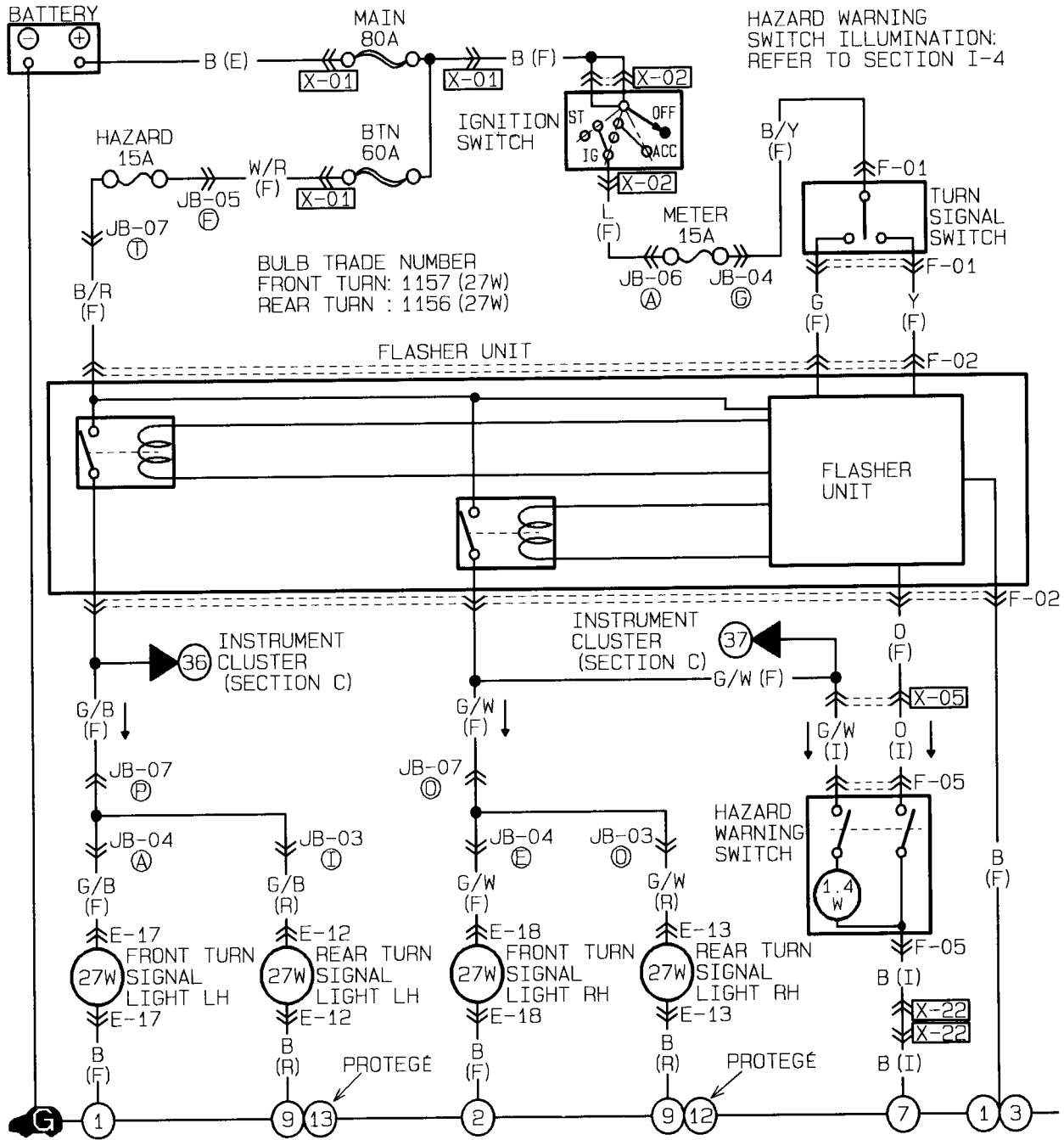

**Explain how each of the following conditions will affect the circuit**

- 1 How will the circuit be affected if there is an open at point **U**.
- 2 How will the circuit be affected if there is an open at point **V**.
- 3 How will the circuit be affected if there is an open at point **W**.
- 4 How will the circuit be affected if there is an open at point **X**.
- 5 How will the circuit be affected if there is an open at point **Y**.
- 6 How will the circuit be affected if there is an open at point **Z**.

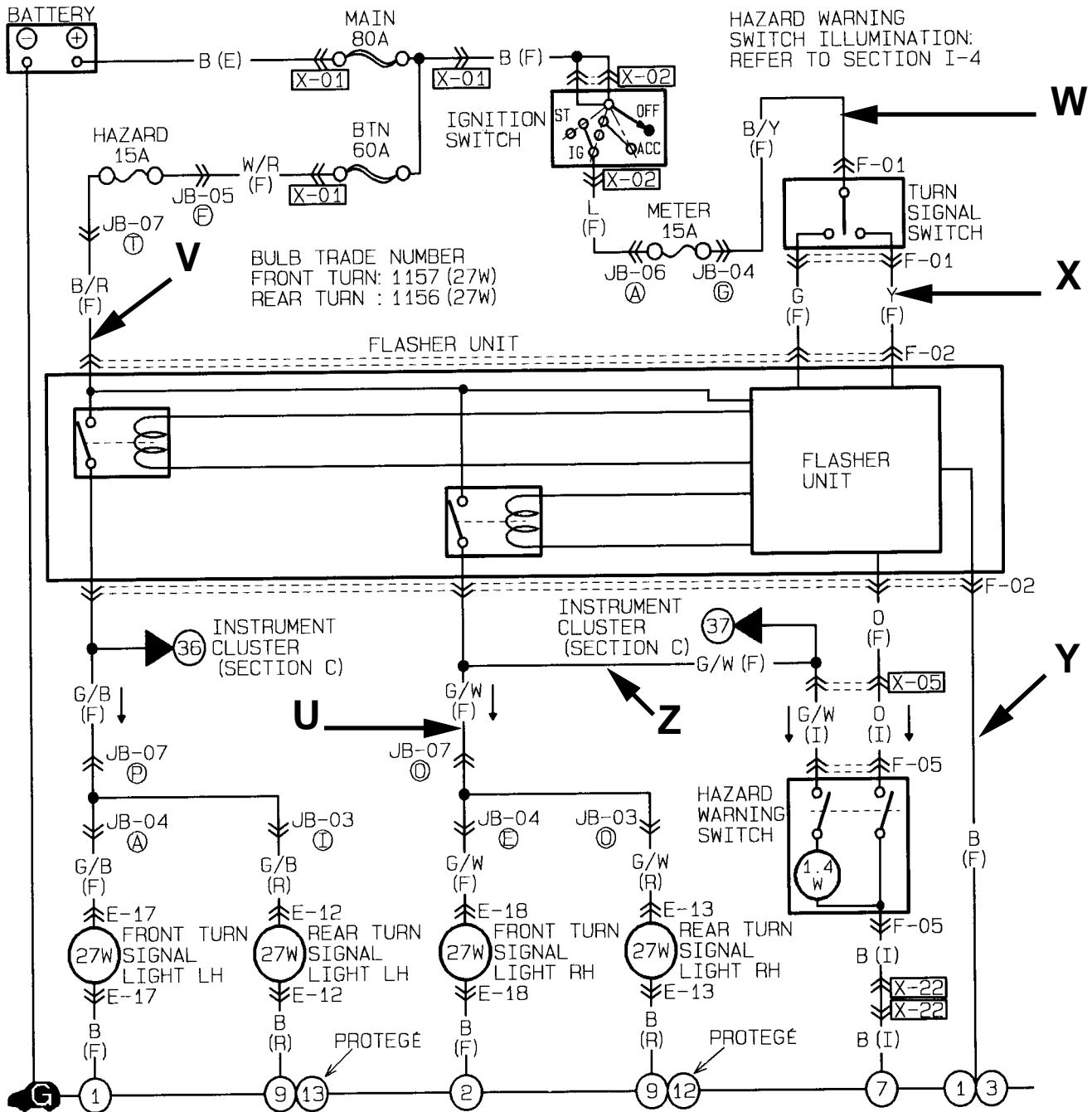

1. Trace in GREEN the portion of the circuit below that you suspect could be at fault.  
Both TURN SIGNAL do not work, but the Hazard lamps do work correctly.
2. Trace in RED the portion of the circuit below that you suspect could be at fault.  
The LEFT TURN SIGNAL does not work. The Hazard Lamps function normally.
3. Trace in BLUE the portion of the circuit below that you suspect could be at fault.  
The HAZARD LAMPS do not work. The Turn Signal Lamps function normally.
4. Trace in ORANGE the portion of the circuit below that you suspect could be at fault.  
Both the HAZARD LAMPS and the TURN SIGNAL LIGHTS do not work in any Position.

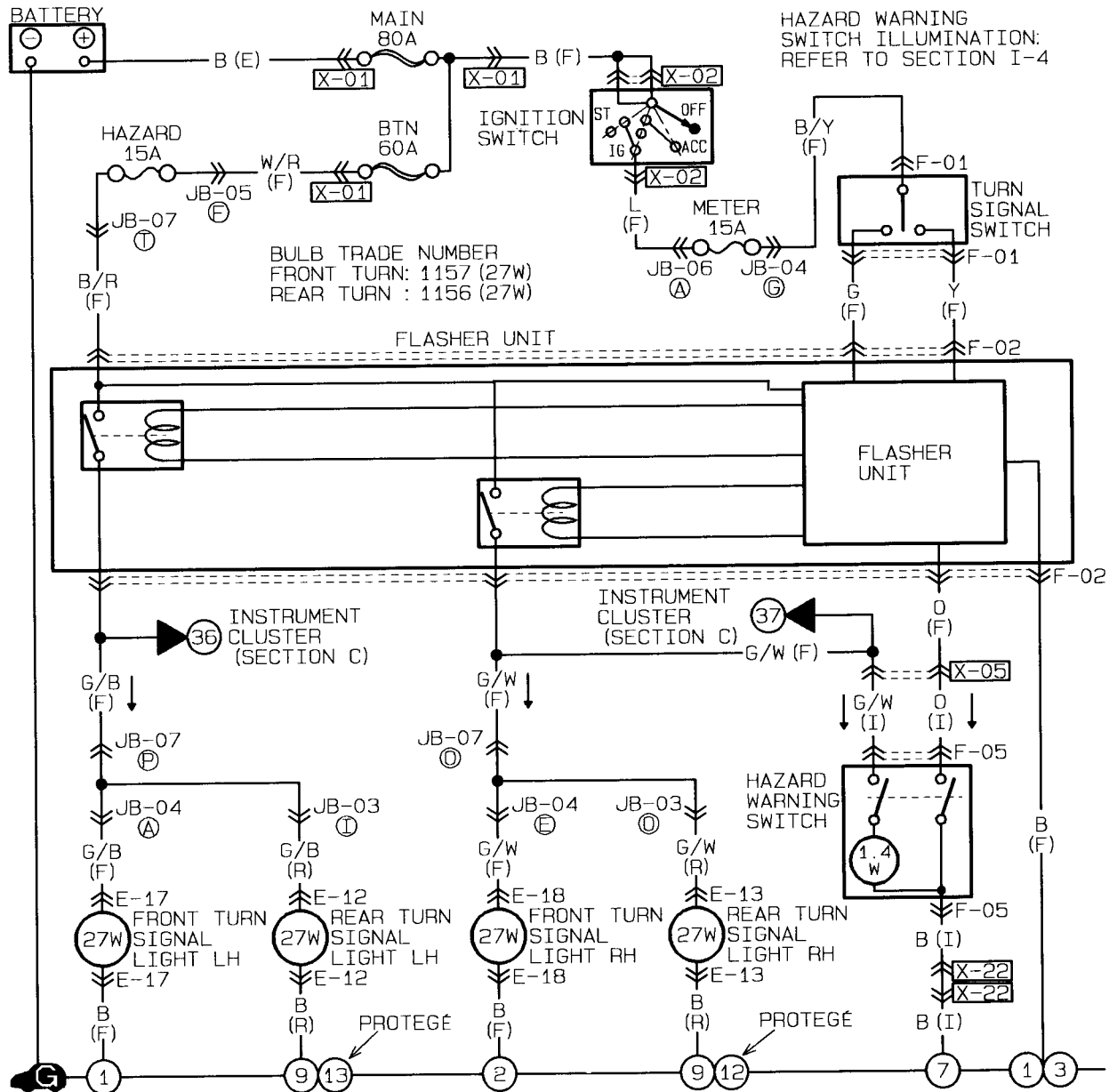

1. Draw in GREEN the RIGHT TURN SIGNAL INPUT signal (control) from the battery to the flasher.
2. Draw in RED the RIGHT TURN SIGNAL LAMP (load) circuit from the battery to the lights.
3. Draw in BLUE the HAZARD INPUT signal (control) from ground to the flasher.

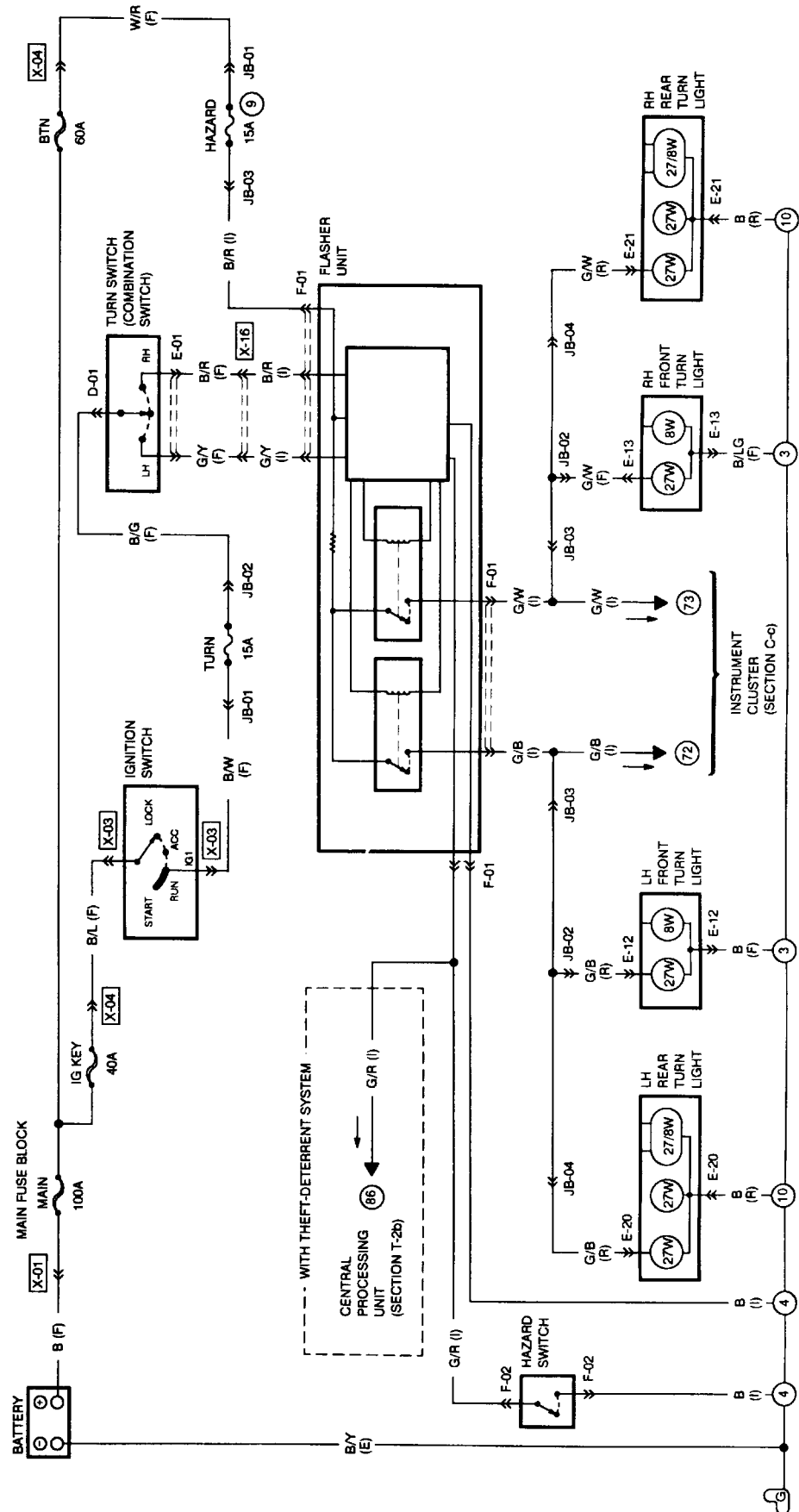



1. Trace in GREEN the portion of the circuit below that you suspect could be at fault. Both TURN SIGNAL do not work, but the Hazard lamps do work correctly.
2. Trace in RED the portion of the circuit below that you suspect could be at fault. The LEFT TURN SIGNAL does not work. The Hazard Lamps function normally.
3. Trace in BLUE the portion of the circuit below that you suspect could be at fault. The HAZARD LAMPS do not work. The Turn Signal Lamps function normally.
4. Trace in ORANGE the portion of the circuit below that you suspect could be at fault. Both the HAZARD LAMPS and the TURN SIGNAL LIGHTS do not work in any Position.

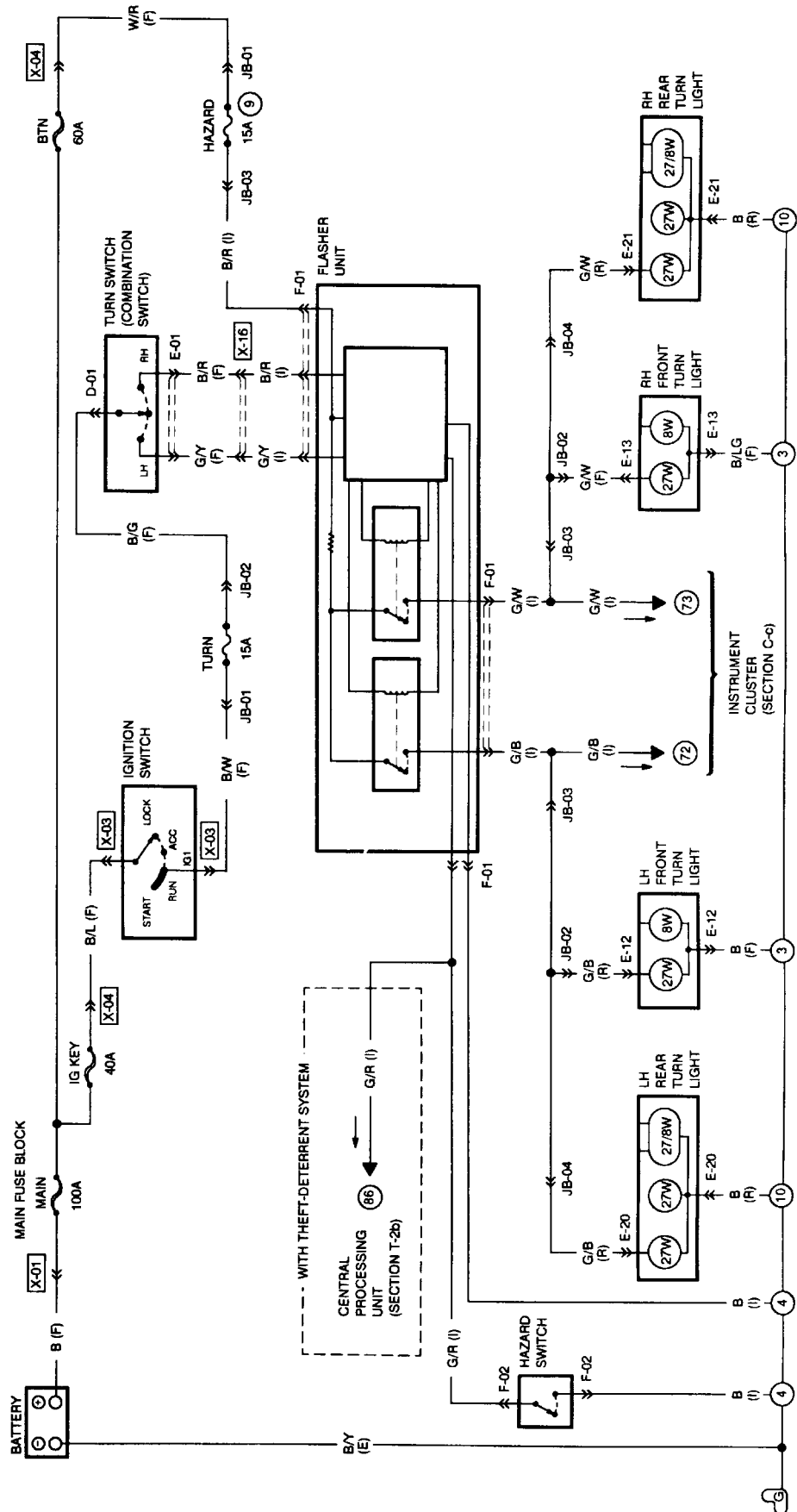



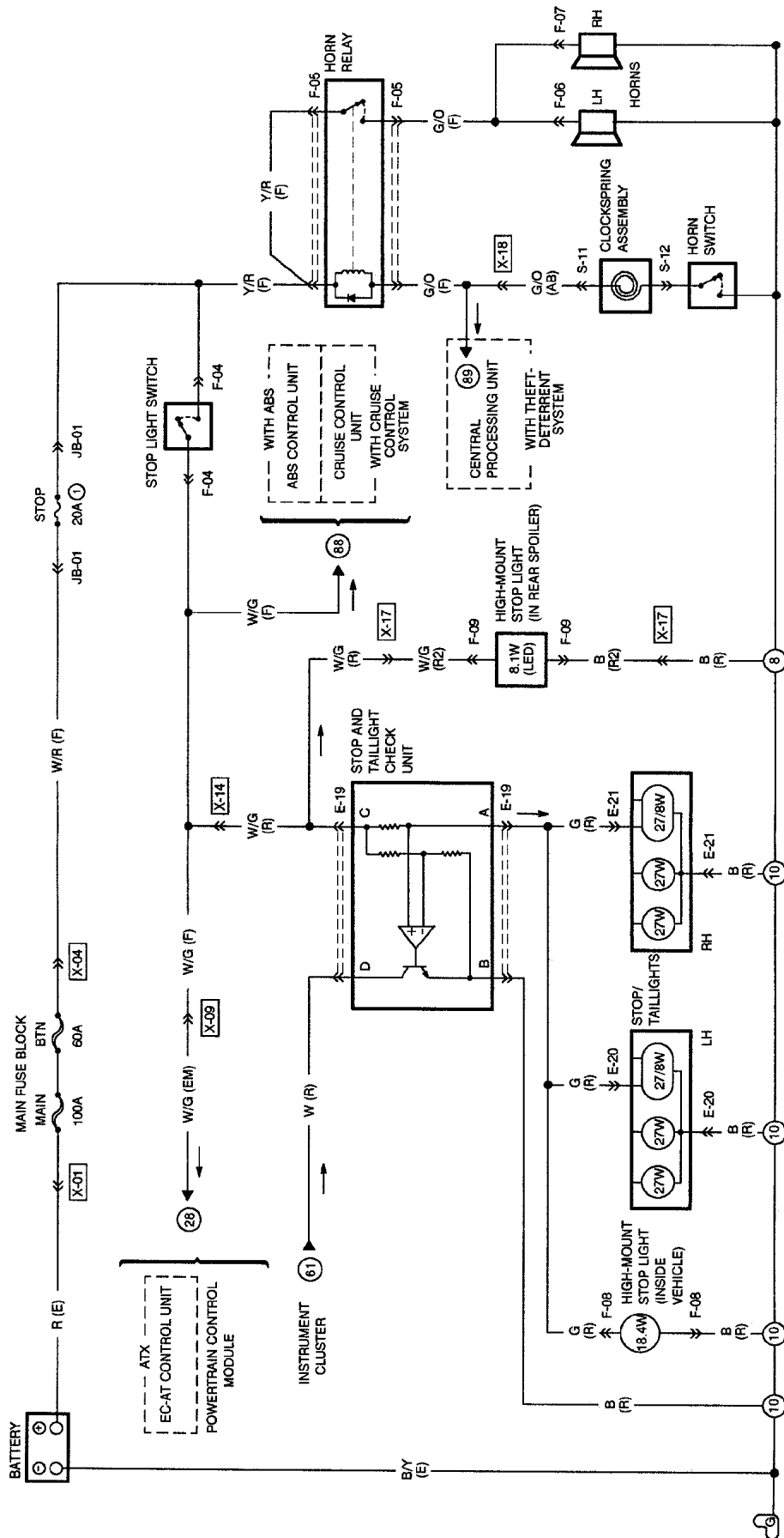

1. Identify the HIGH MOUNT STOP LIGHT circuit WITHOUT the Rear Spoiler. Draw that circuit in GREEN from the battery to ground.
2. Identify the HIGH MOUNT STOP LIGHT circuit WITH a Rear Spoiler. Draw that circuit in Blue from the battery to ground.
3. Draw in RED the B+ current path from the STOP LIGHT SWITCH to the Stop Light bulbs.

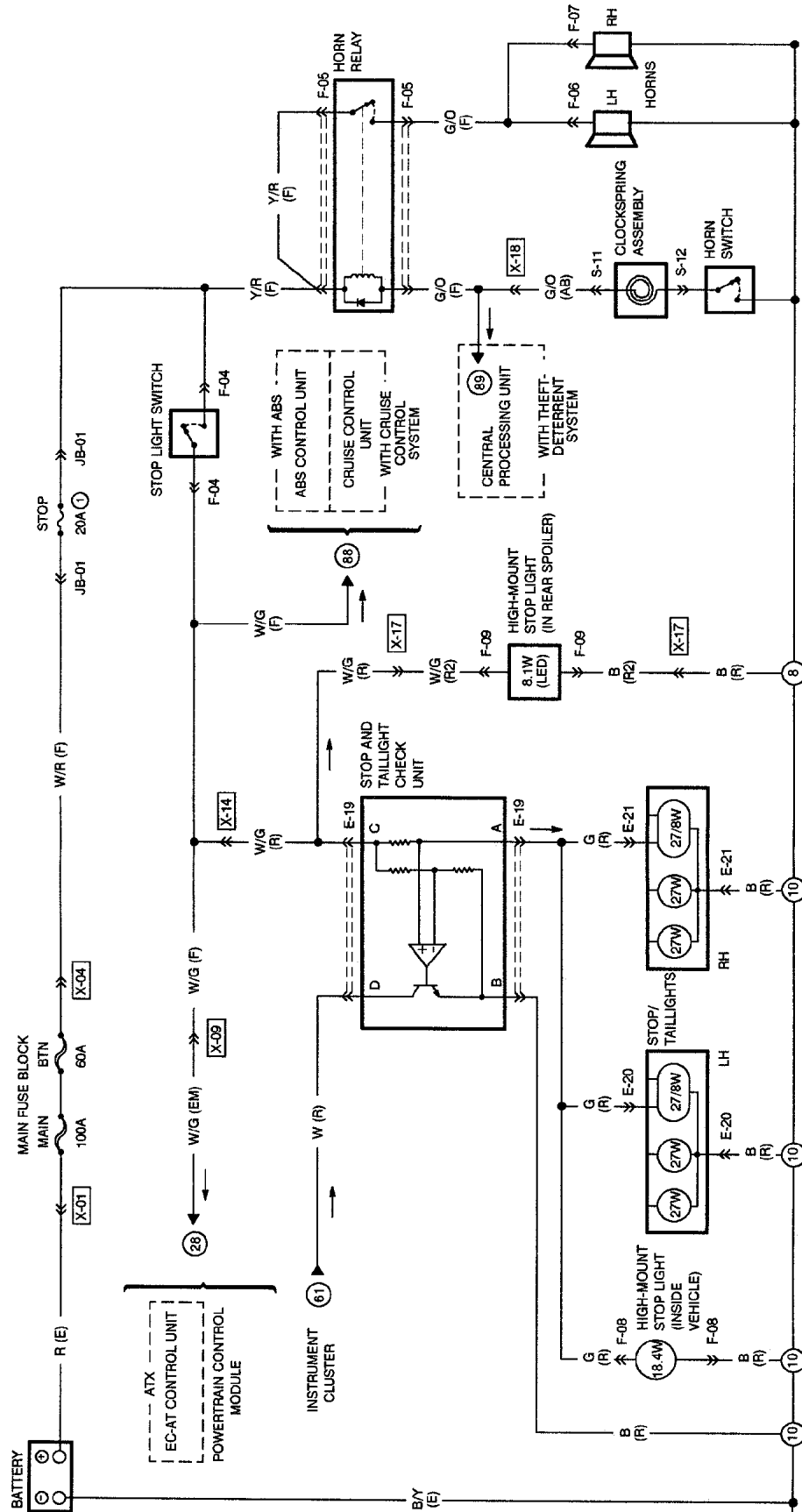

1. THE STOP LIGHT SWITCH IS PLACED IN THE CLOSED POSITION. Draw the BLUE the POSITIVE B+ SIDE of the circuit. Everything that is Positive (B+) with the Ign Key OFF.
2. THE STOP LIGHT SWITCH IS PLACED IN THE OPEN POSITION. Draw the GREEN the GROUND SIDE of the circuit. Everything that is ground (Negative) with the Ign Key OFF..

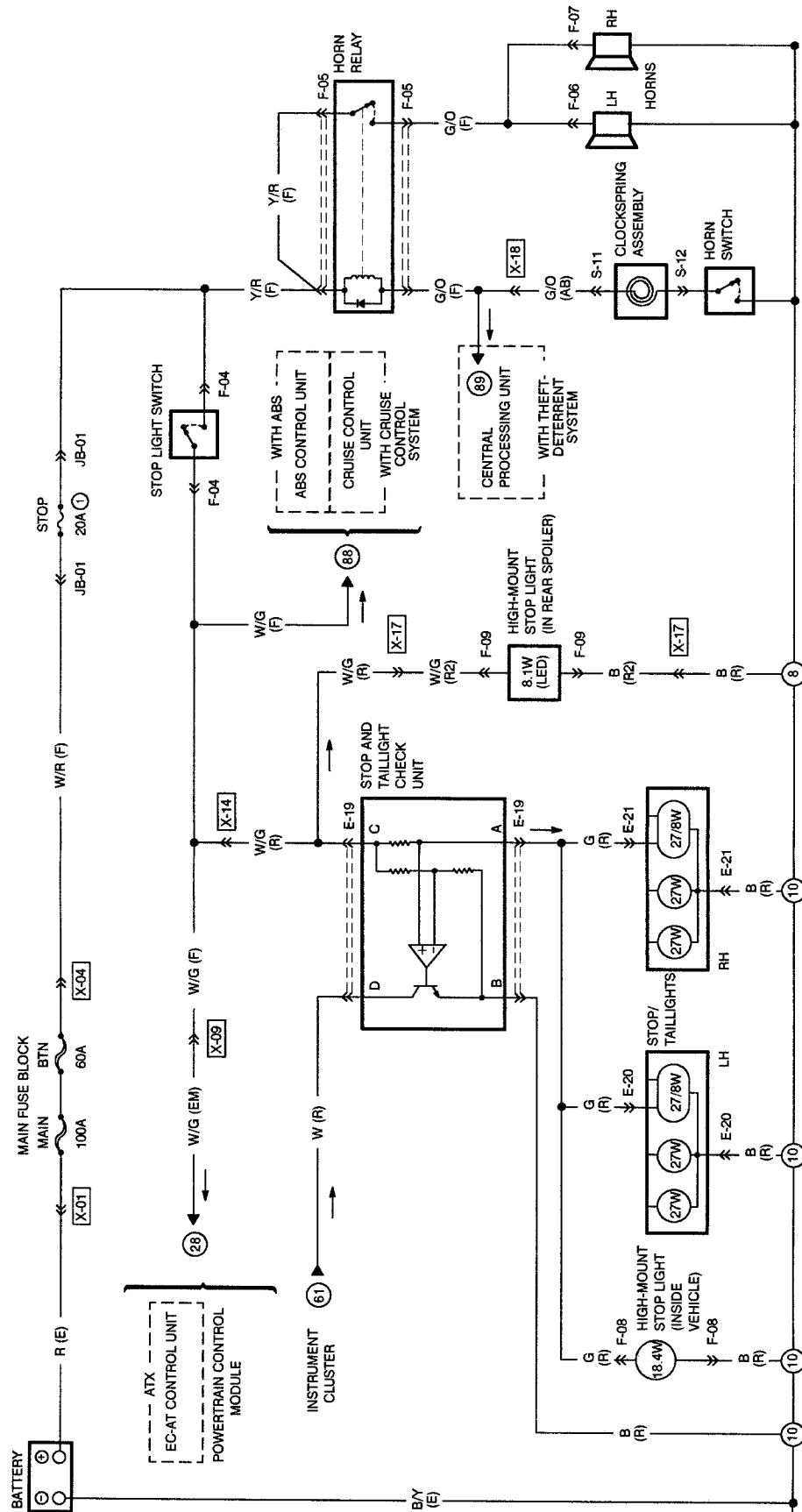

1. With the STOP LIGHT Switch in the OFF position, what voltage would you expect to find at point **V**, **W**, **X**, **Y**, & **Z**?  
(Note: Ignition Key is in the ON position)
2. With the STOP LIGHT Switch in the ON position, what voltage would you expect to find at point **V**, **W**, **X**, **Y**, & **Z**?  
(Note: Ignition Key is in the OFF position)
3. With a STOP LIGHT bulb burned out, what voltage would you expect to find at point **Y**? B+ or Ground.

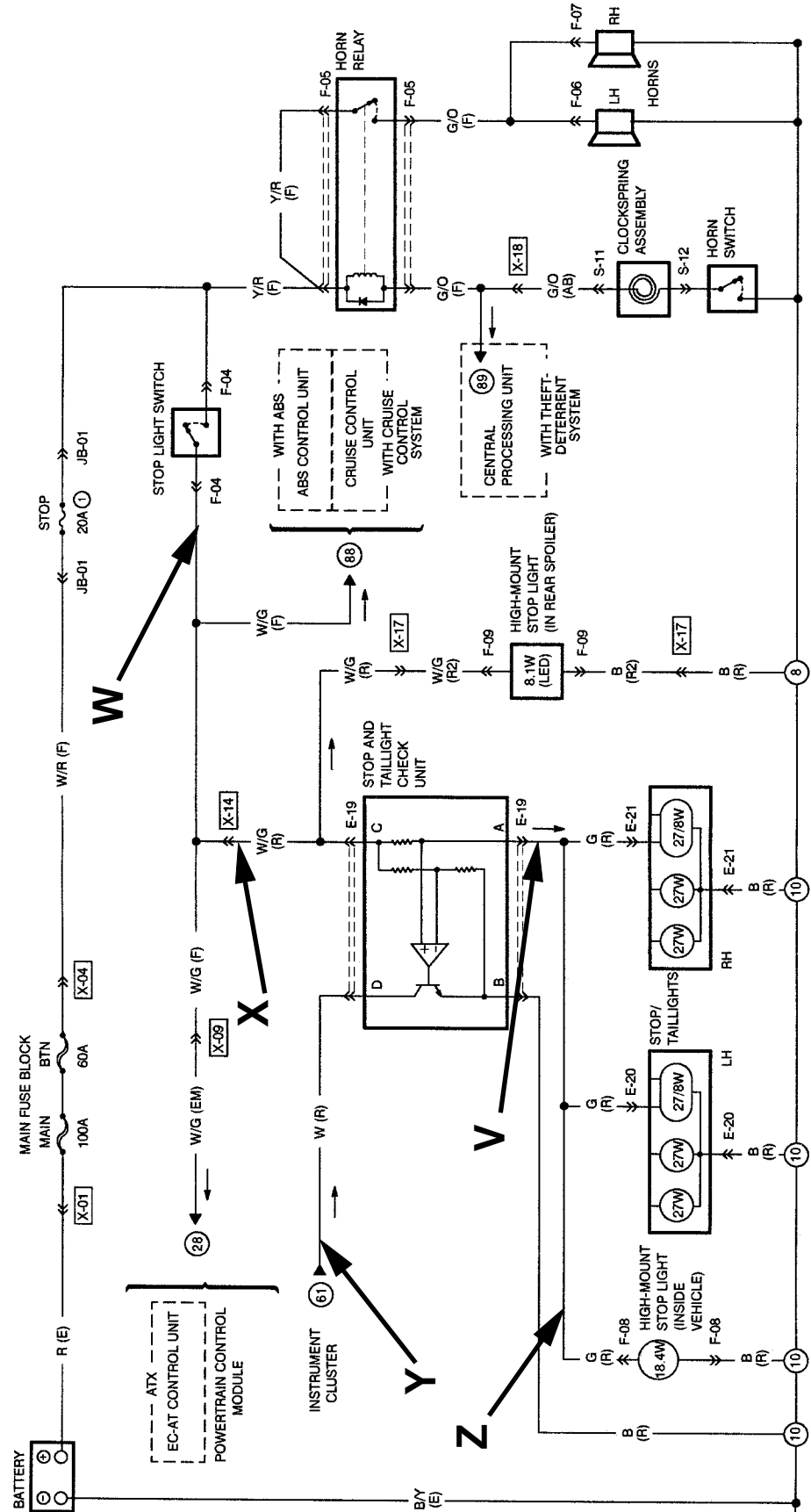

- 1. How will the circuit be affected if there is an open at point V?
- 2. How will the circuit be affected if there is an open at point W?
- 3. How will the circuit be affected if there is an open at point X?
- 4. How will the circuit be affected if there is an open at point Y?
- 5. How will the circuit be affected if there is an open at point Z?

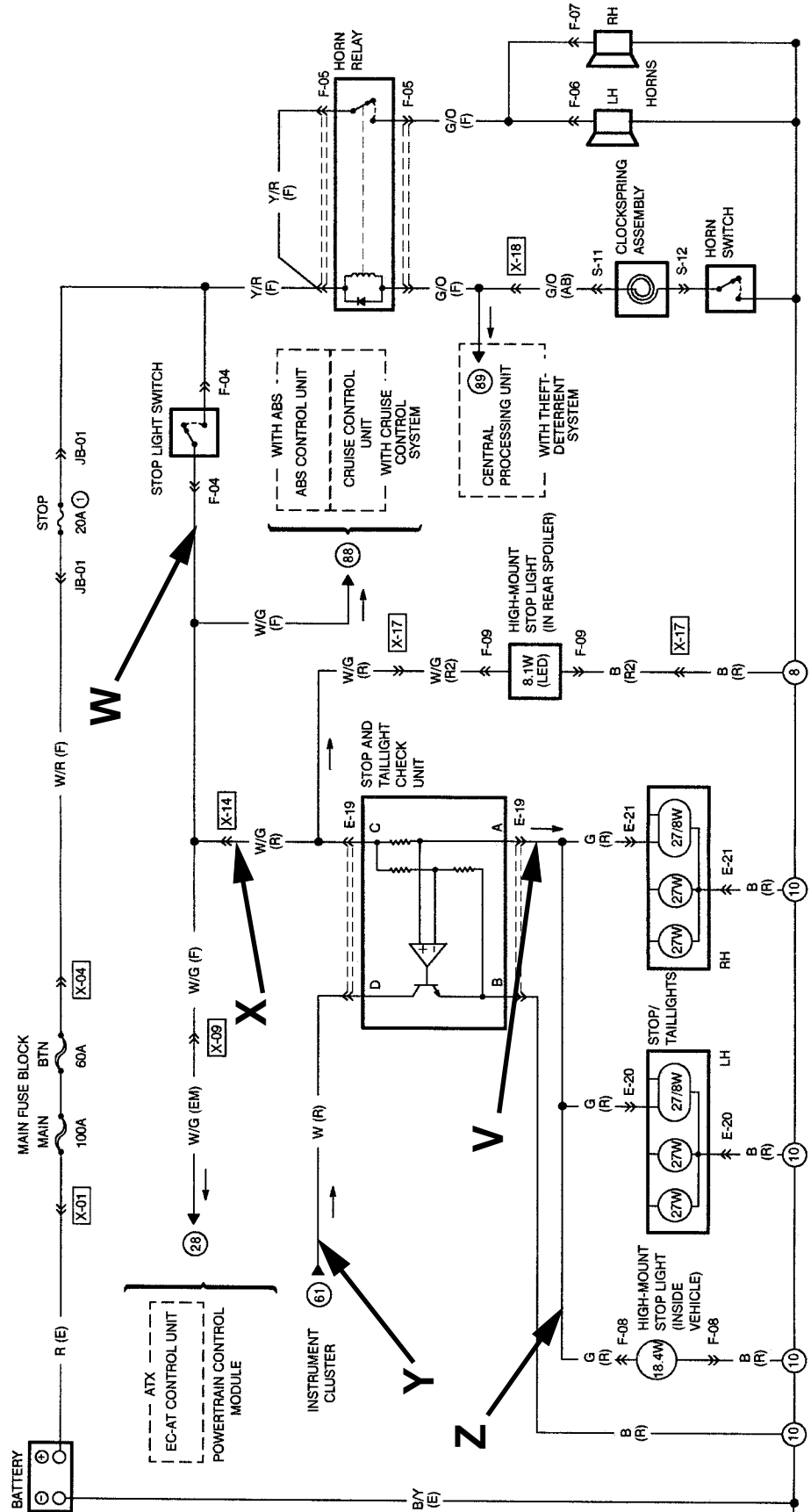

1. On a vehicle **with a rear spoiler**. The Stop Lights do *not* work, but the High-Mount Stop Light works fine. Trace in GREEN the portion of the circuit below that could be at fault.
2. On a vehicle **with a rear spoiler**. The High-Mount Stop Light *does not* work, but the Stop lights work. Trace in BLUE the portion of the circuit below that could be at fault.
3. On a vehicle **with a rear spoiler**. A single Stop Light in burned out, but the Rear Warning Lamp indicator doesn't light. Trace in RED the portion of the circuit that could be at fault.
4. On a vehicle **without a rear spoiler**. None of the Stop Lights work. Trace in ORANGE the portion of the circuit below that could be at fault. The horn works correctly.

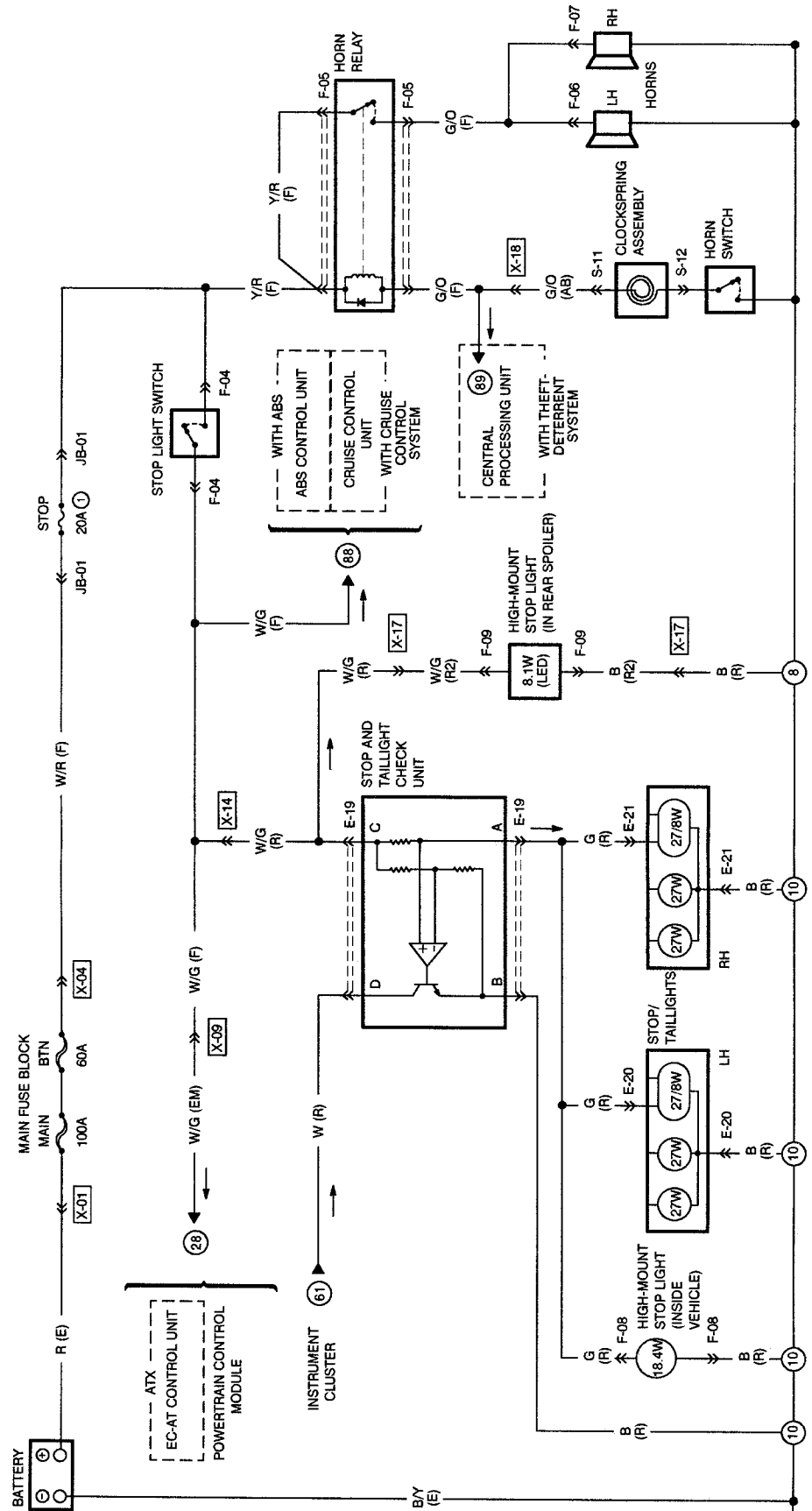

# MAZDA

## Horn / Backup Lamps Worksheets

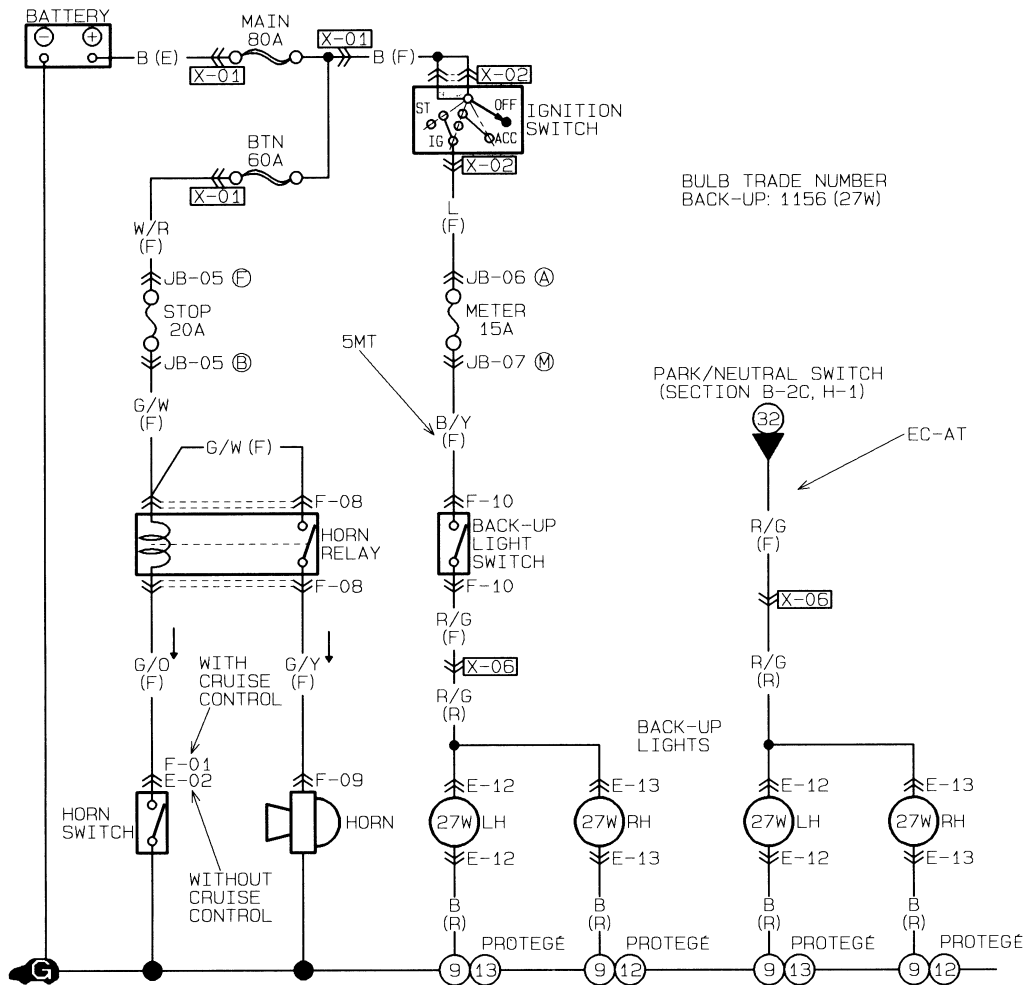

1. Draw in GREEN the HORN CONTROL circuit from the battery to ground.
2. Draw in RED the HORN circuit from the battery to ground.
3. Draw in BLUE the BACKUP LAMP circuit from the battery to ground.

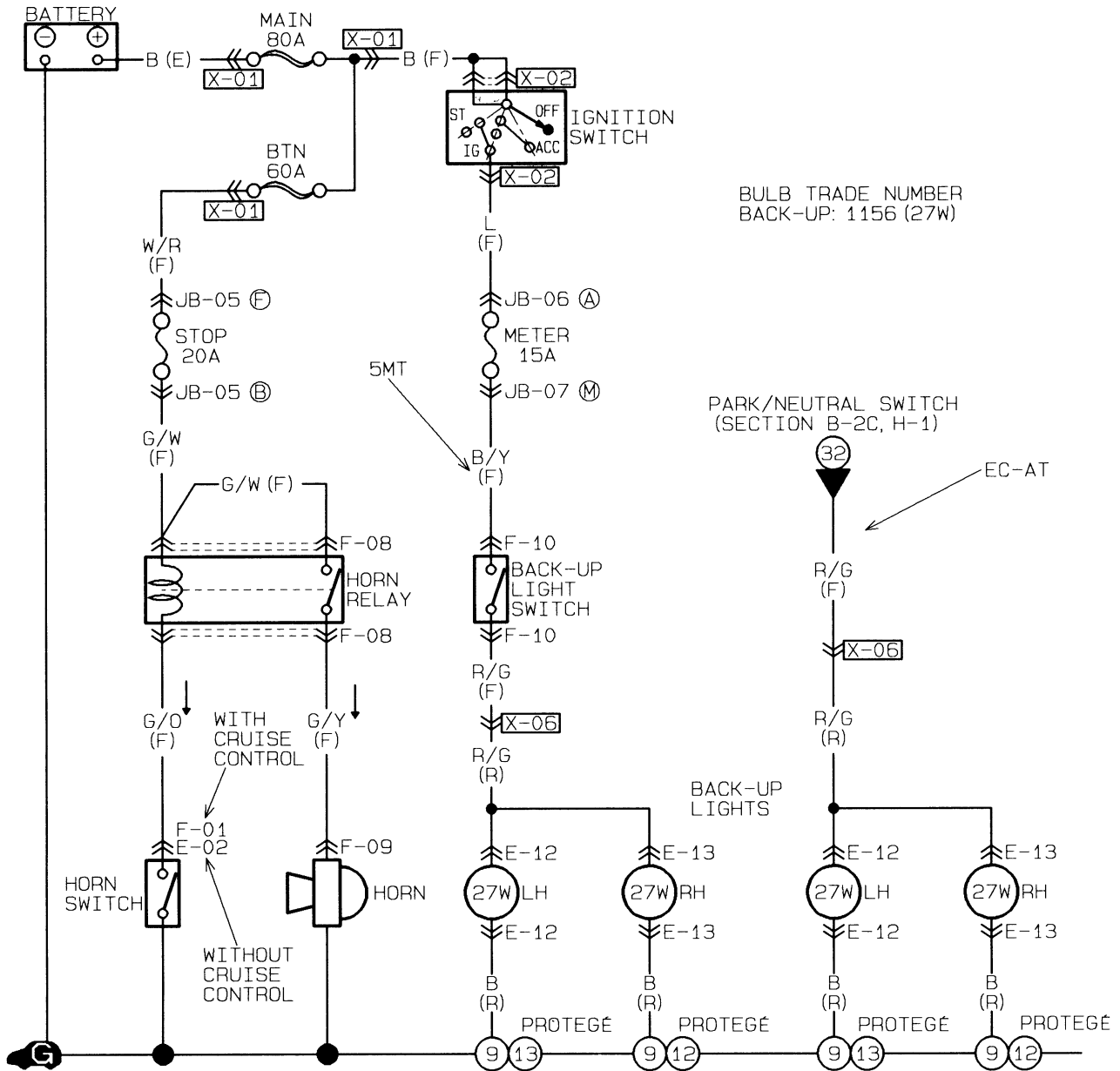



# MAZDA

## Power Windows

### Worksheets

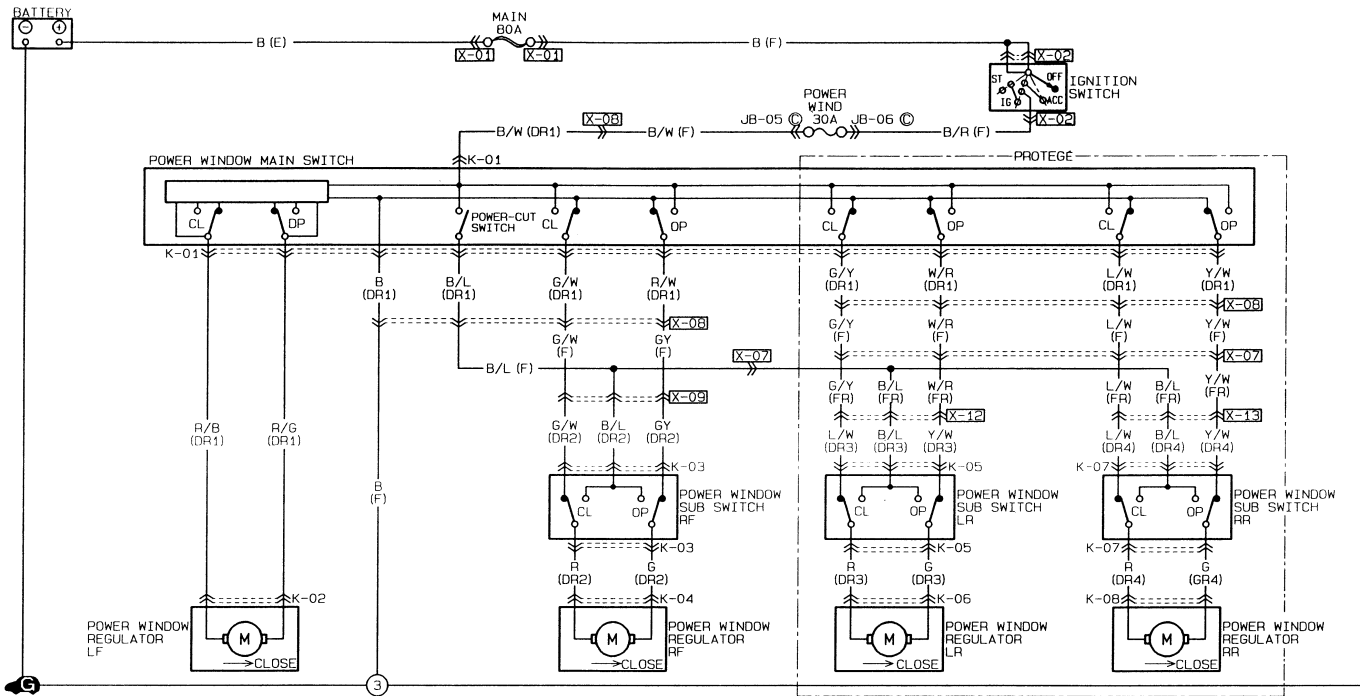

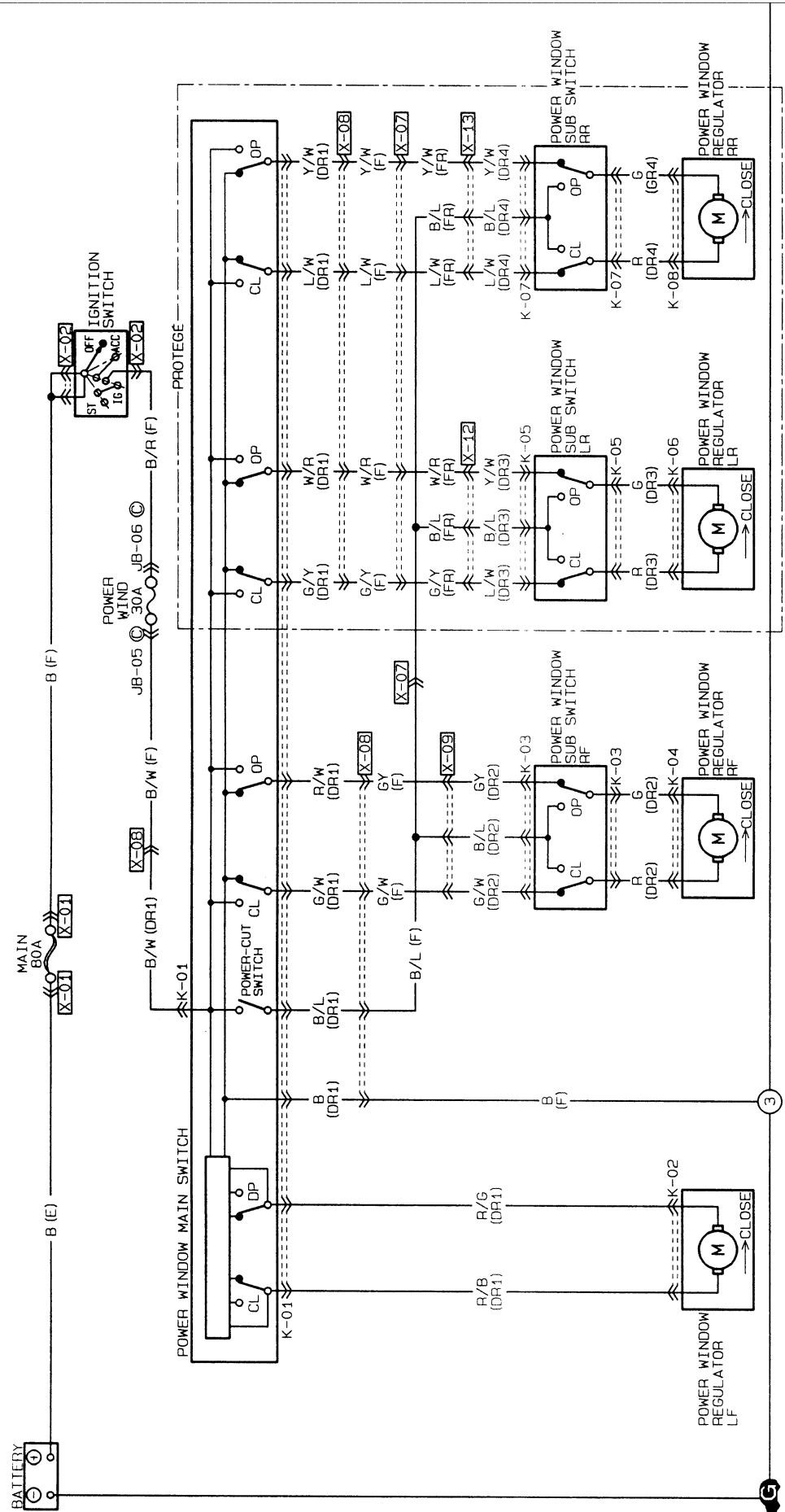



**While moving the LEFT REAR window in the CLOSED position from the PASSENGER SUB SWITCH.**

1. Trace in RED the POSITIVE power flow from the fuse to the motor.
2. Trace in BLUE the NEGATIVE power flow from the motor to ground.

**While moving the RIGHT REAR window in the CLOSED position from the MASTER SWITCH.**

1. Trace in GREEN the POSITIVE power flow from the fuse to the motor.
2. Trace in ORANGE the NEGATIVE power flow from the motor to ground.

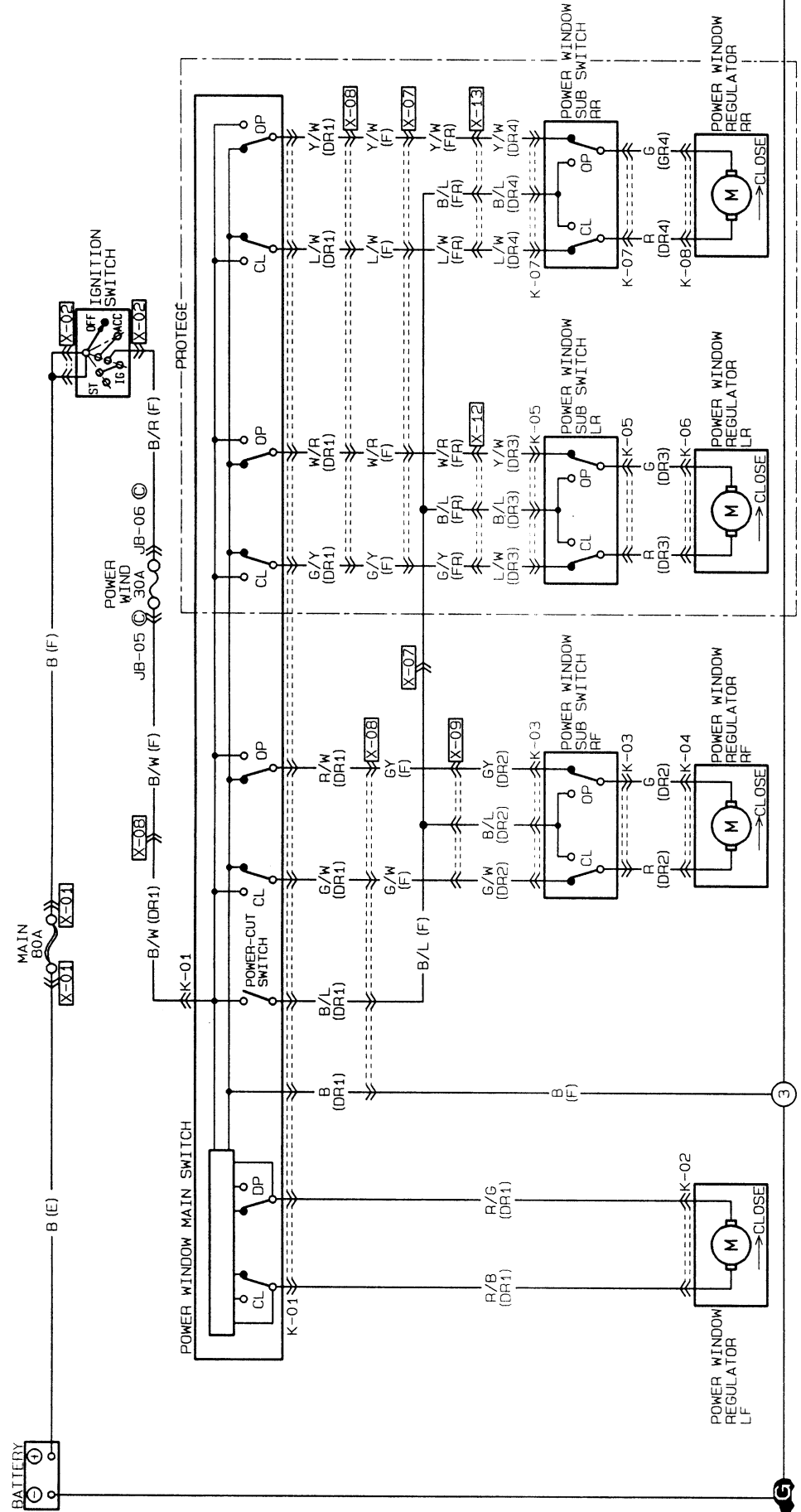

**While moving the RIGHT REAR window in the CLOSED position from the PASSENGER SUB SWITCH.**

1. Trace in RED the POSITIVE power flow from the fuse to the motor.
2. Trace in BLUE the NEGATIVE power flow from the motor to ground.

**While moving the LEFT REAR window in the CLOSED position from the MASTER SWITCH.**

1. Trace in GREEN the POSITIVE power flow from the fuse to the motor.
2. Trace in ORANGE the NEGATIVE power flow from the motor to ground.

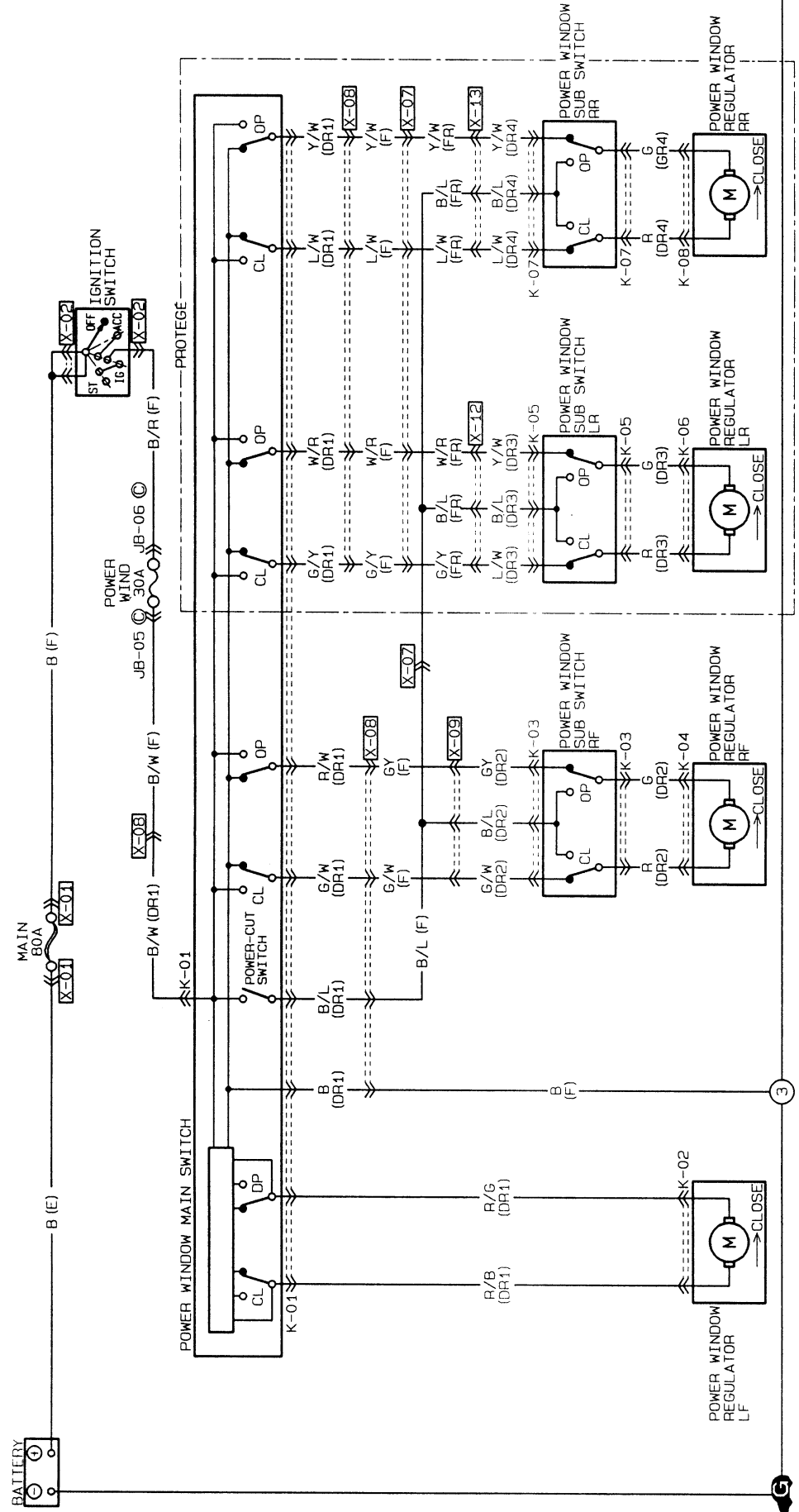

1. How will the circuit be affected if there is an open at point T.
2. How will the circuit be affected if there is an open at point U.
3. How will the circuit be affected if there is an open at point V.
4. How will the circuit be affected if there is an open at point W.
5. How will the circuit be affected if there is an open at point X.
6. How will the circuit be affected if there is an open at point Y.
7. How will the circuit be affected if there is an open at point Z.

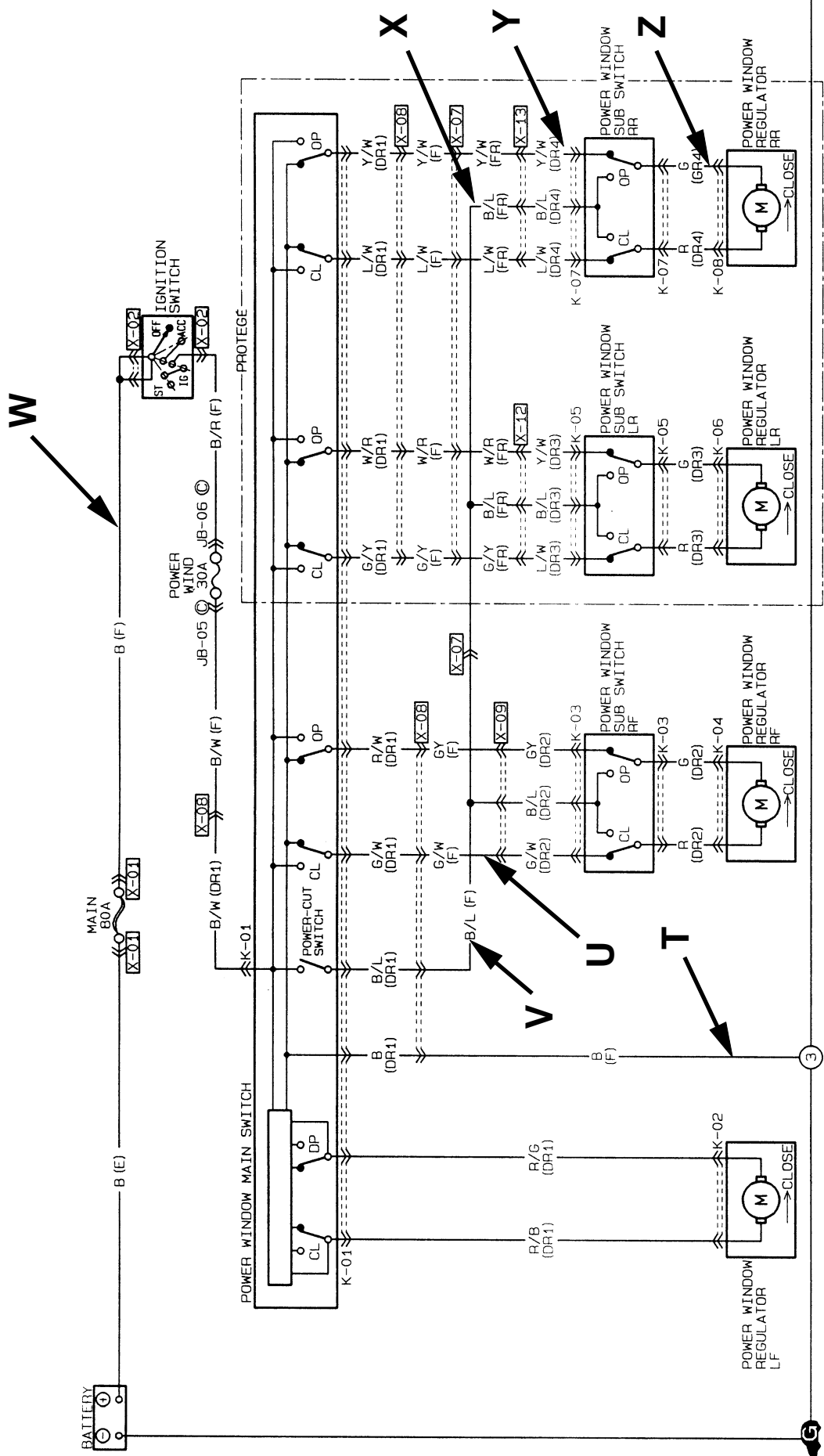



1. The LEFT REAR Window will not OPEN or CLOSE from the SUB Window Switch. However, the window will OPEN and CLOSE from the master switch.  
Trace in GREEN the areas where you suspect the problem could be.
2. The RIGHT FRONT Window will OPEN but NOT CLOSE from the Master Window Switch. However, when the Sub Switch is used, the window will OPEN and CLOSE.  
Trace in ORANGE the areas where you suspect the problem could be.
3. Only the LEFT FRONT Window (DRIVER SIDE) will OPEN or CLOSE from the MASTER Window Switch. The other windows will OPEN and CLOSE only from the SUB switches.  
Trace in BLUE the areas where you suspect the problem could be.

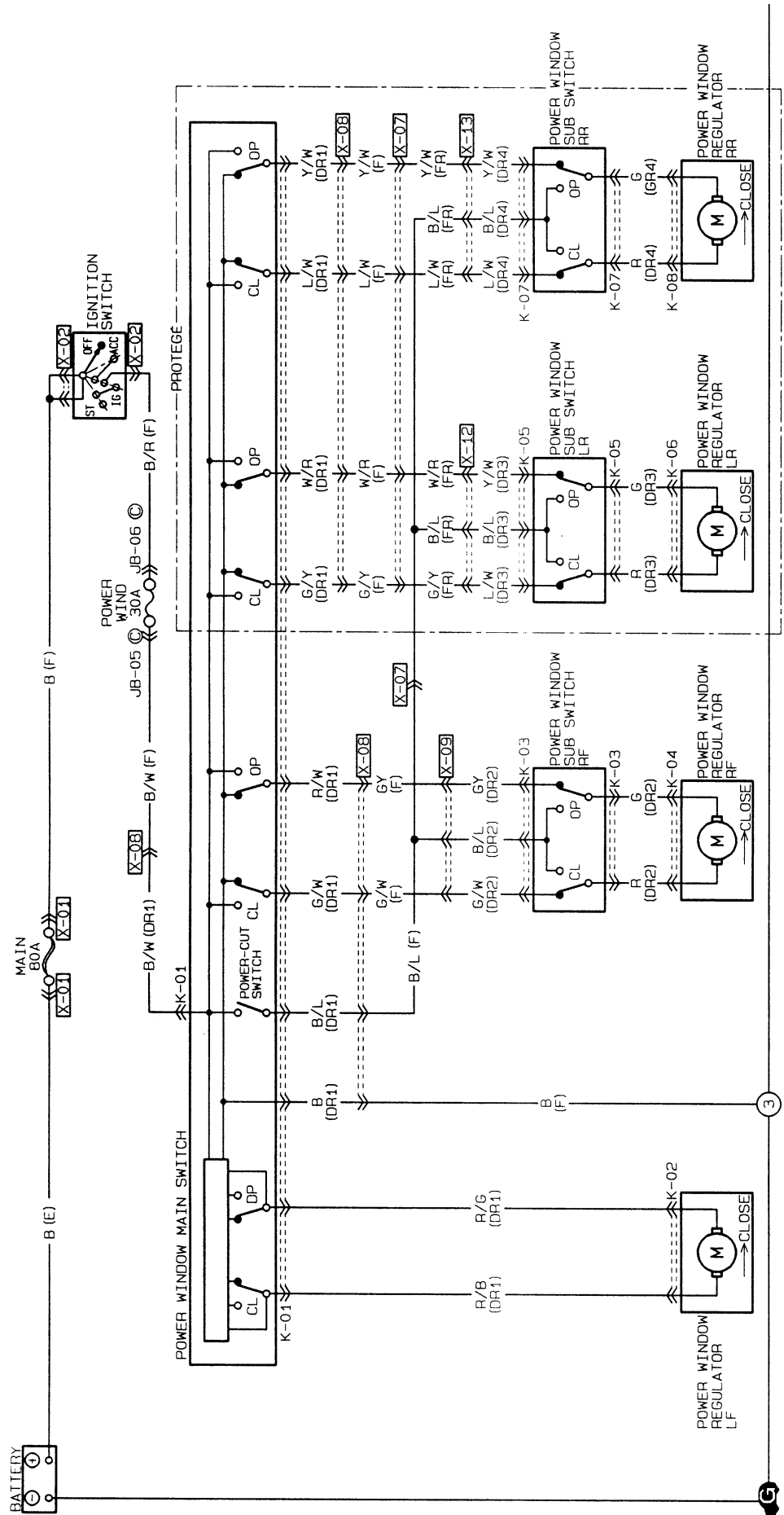

# MAZDA

## Power Mirrors

### Worksheets

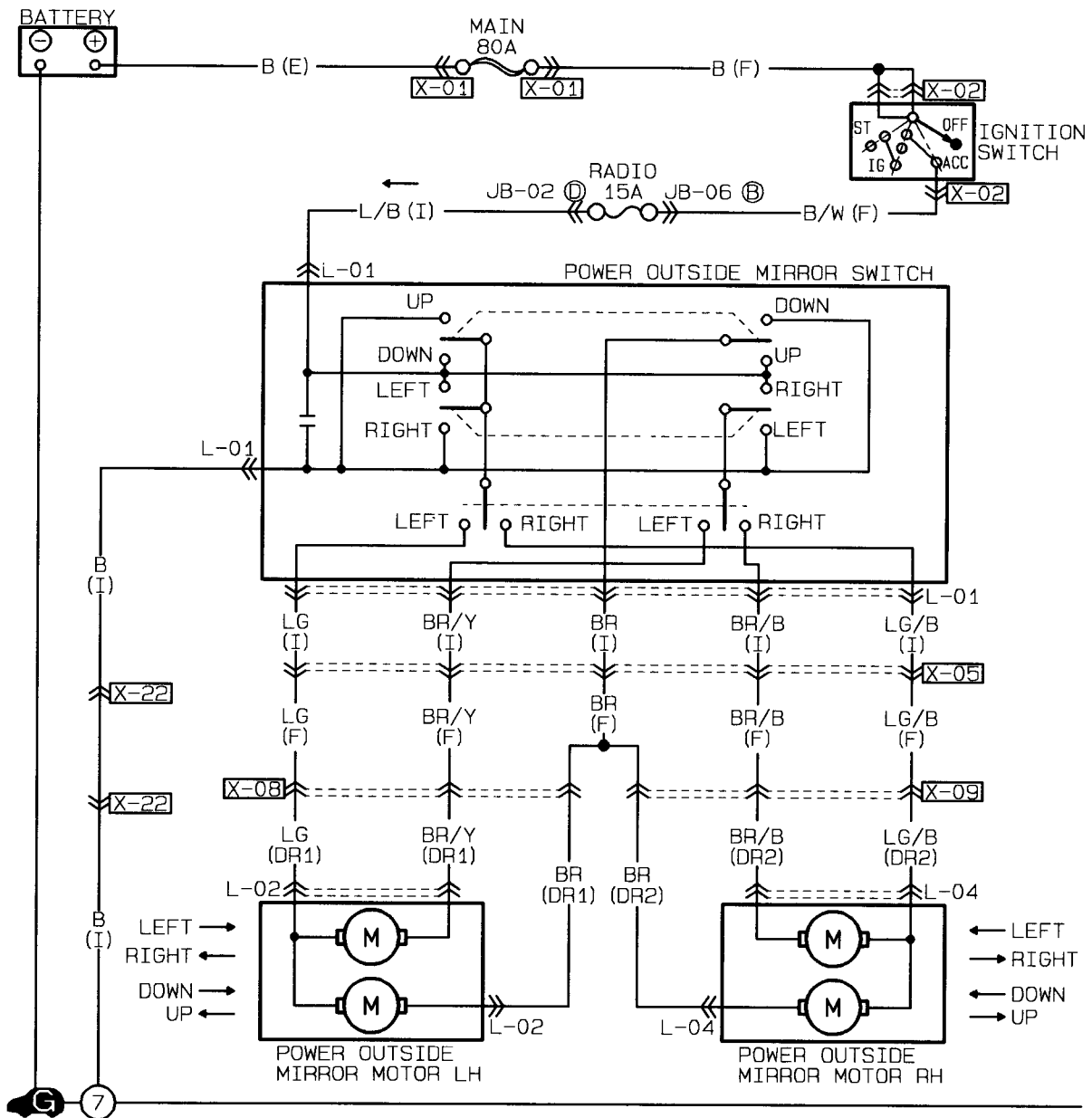

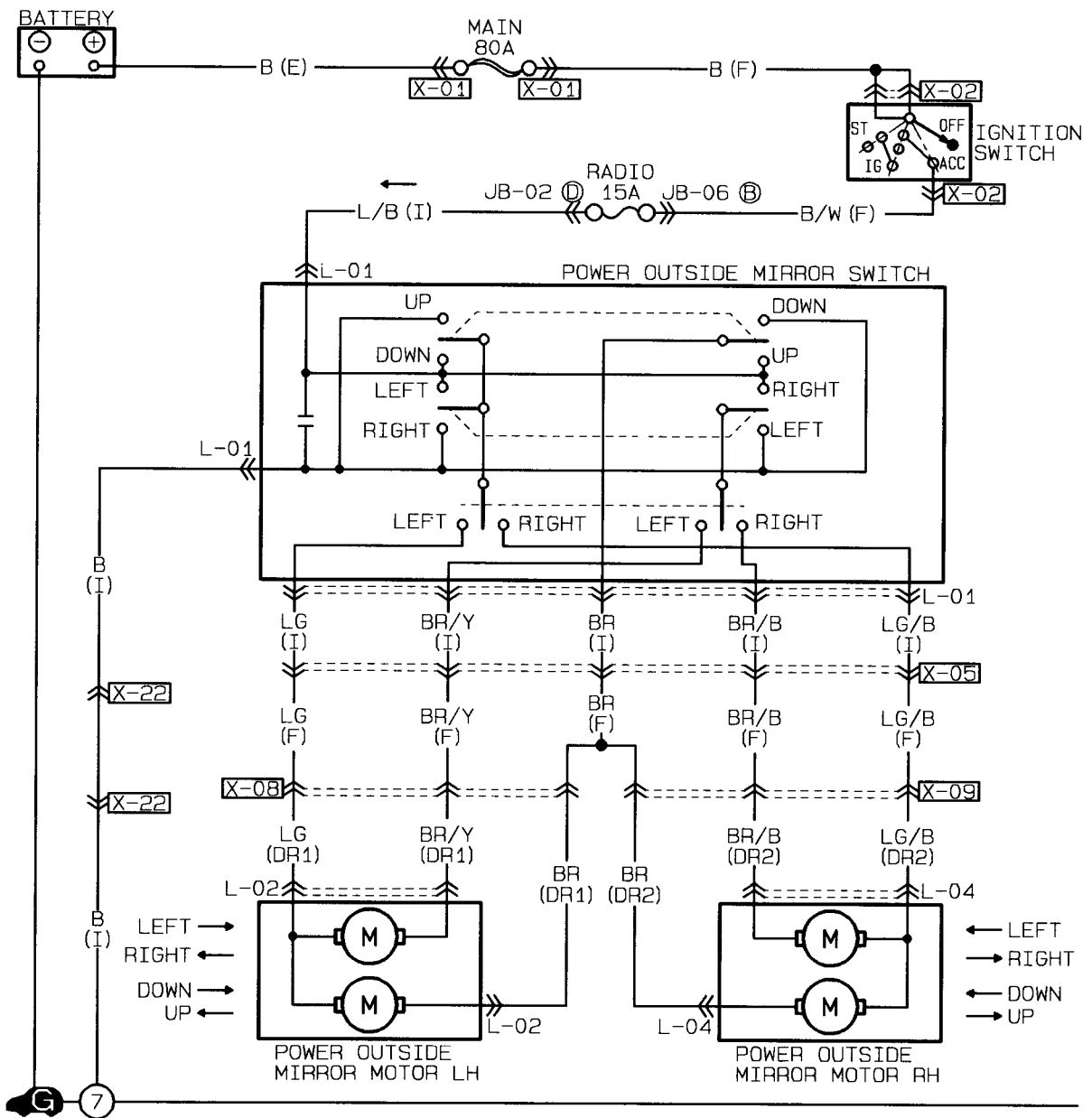

While moving the LEFT SIDE MIRROR in the UP position.

1. Trace in RED the POSITIVE power flow from the battery to the motor.
2. Trace in BLUE the NEGATIVE power flow from the motor to ground.

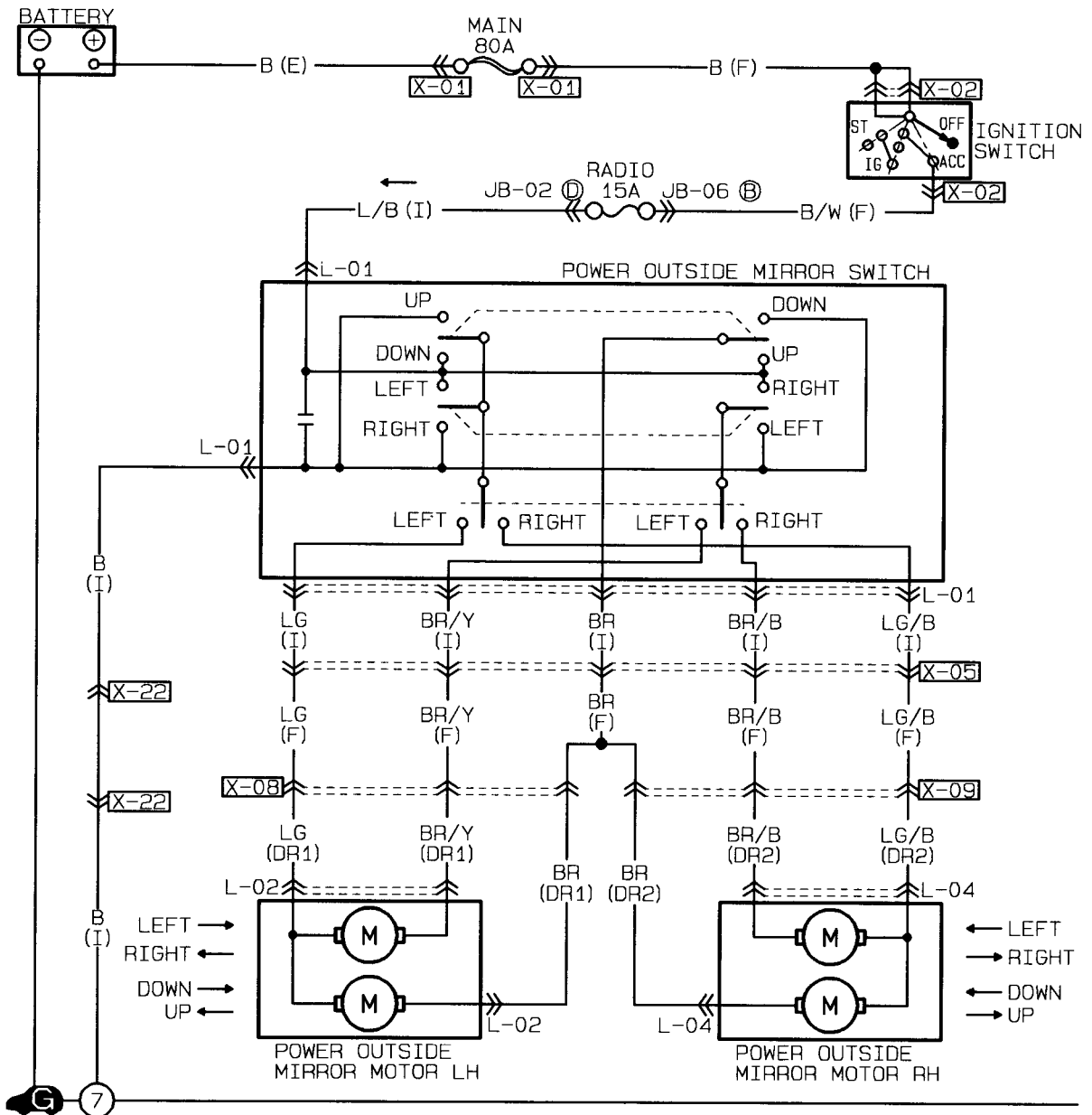

While moving the RIGHT SIDE MIRROR to the RIGHT.

1. Trace in RED the POSITIVE power flow from the battery to the motor.
2. Trace in BLUE the NEGATIVE powerflow from the motor to ground.

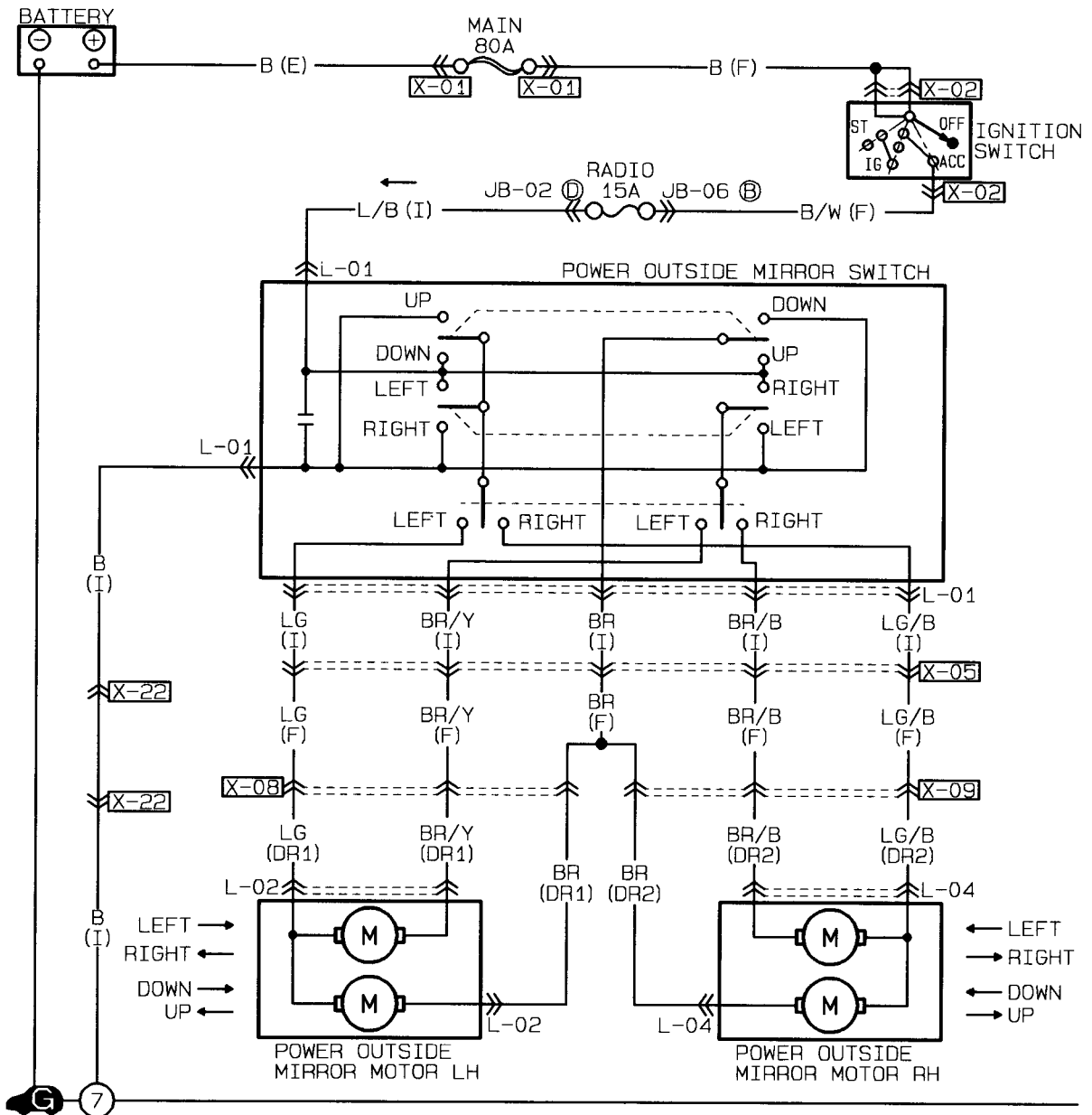

1. While moving the LEFT SIDE MIRROR to the LEFT.  
Trace in RED the current flow from the battery to ground.
2. While moving the LEFT SIDE MIRROR to the DOWN.  
Trace in Blue the current flow from the battery to ground.

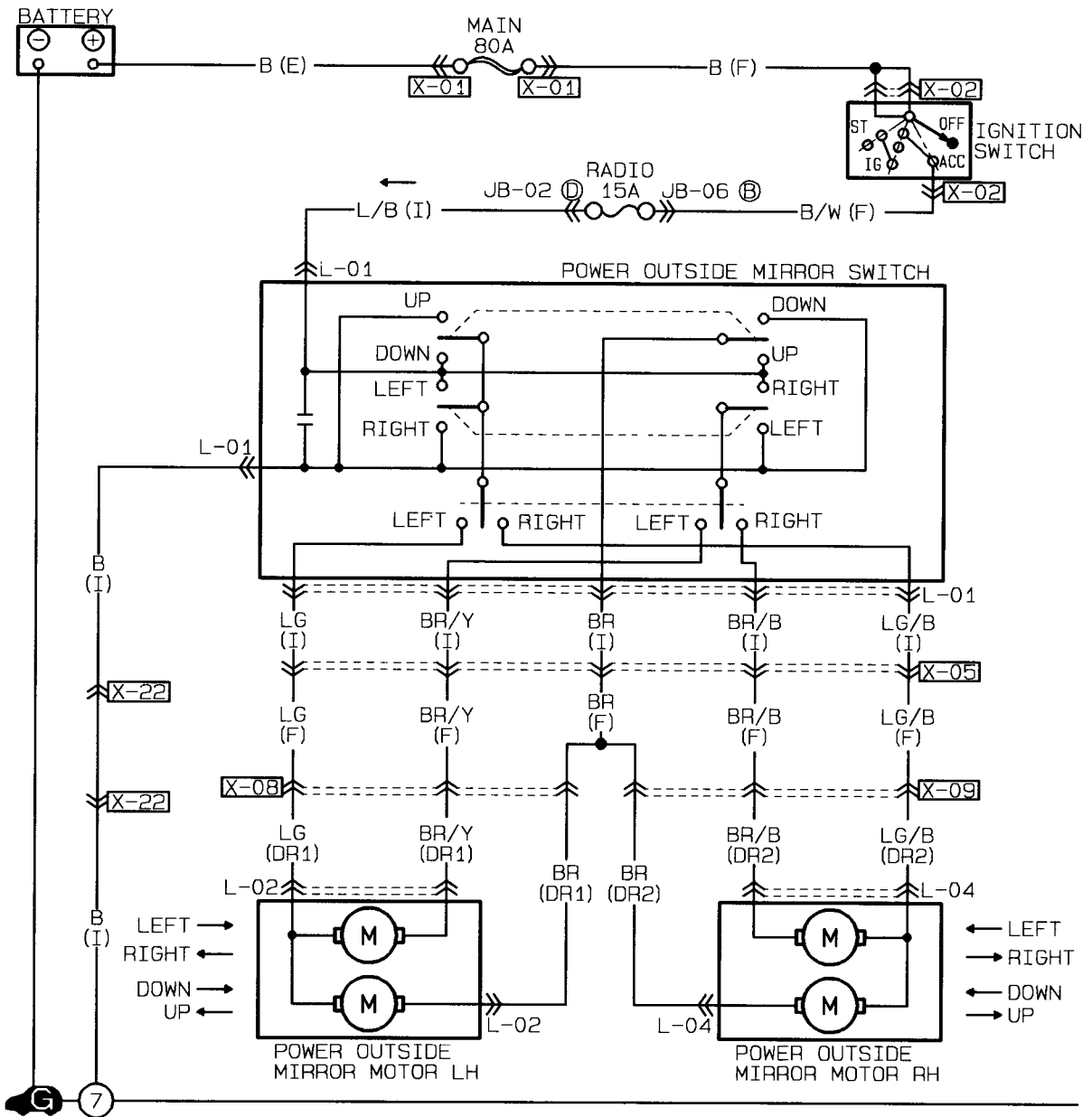

1. While moving the **RIGHT SIDE MIRROR to the LEFT**.  
Trace in RED the current flow from the battery to ground.
2. While moving the **RIGHT SIDE MIRROR to the UP**.  
Trace in Blue the current flow from the battery to ground.

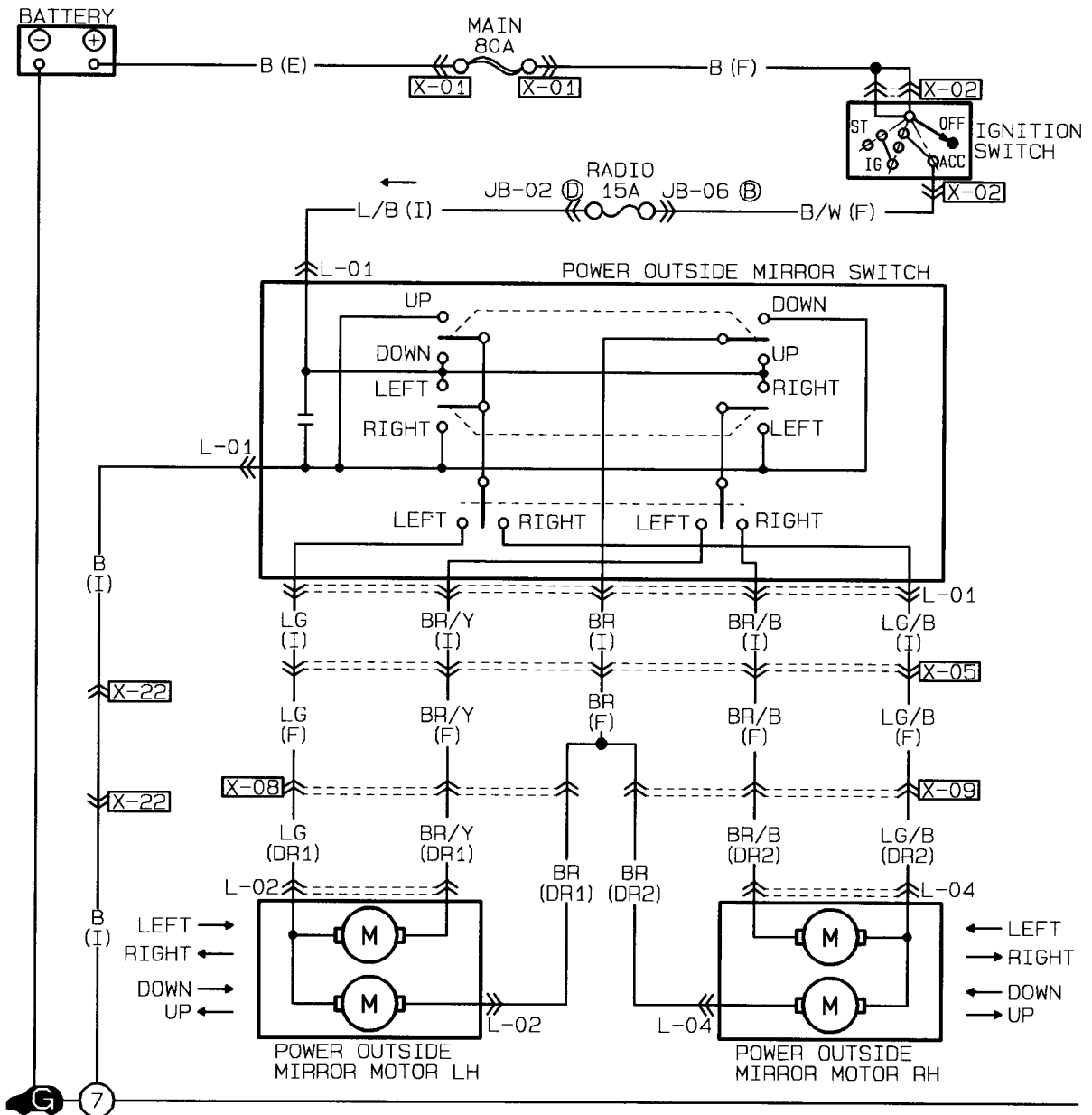

Determine what the affect will be on the following circuit.

1. How will the circuit be affected if there is an open at point **V**.
2. How will the circuit be affected if there is an open at point **W**.
3. How will the circuit be affected if there is an open at point **X**.
4. How will the circuit be affected if there is an open at point **Y**.
5. How will the circuit be affected if there is an open at point **Z**.

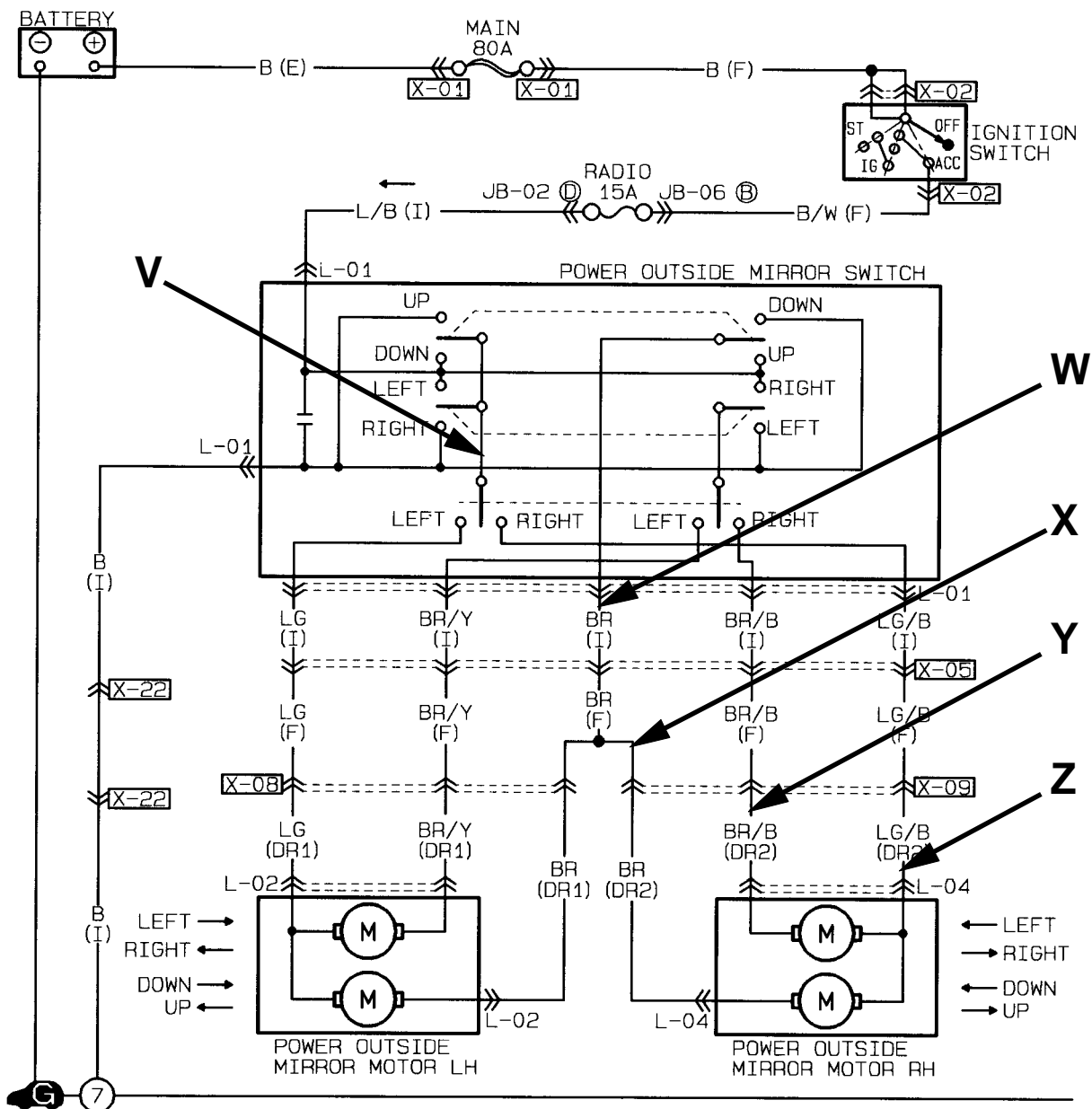

**PROBLEM #1**

The LEFT MIRROR will NOT adjust UP or DOWN. However, the LEFT MIRROR will adjust LEFT and RIGHT. The RIGHT MIRROR functions correctly. Trace in BLUE the areas where the problem could be.

**PROBLEM #2**

The RIGHT MIRROR will NOT adjust UP,DOWN, LEFT,or RIGHT. The LEFT MIRROR functions correctly. Trace in RED the areas where the problem could be.

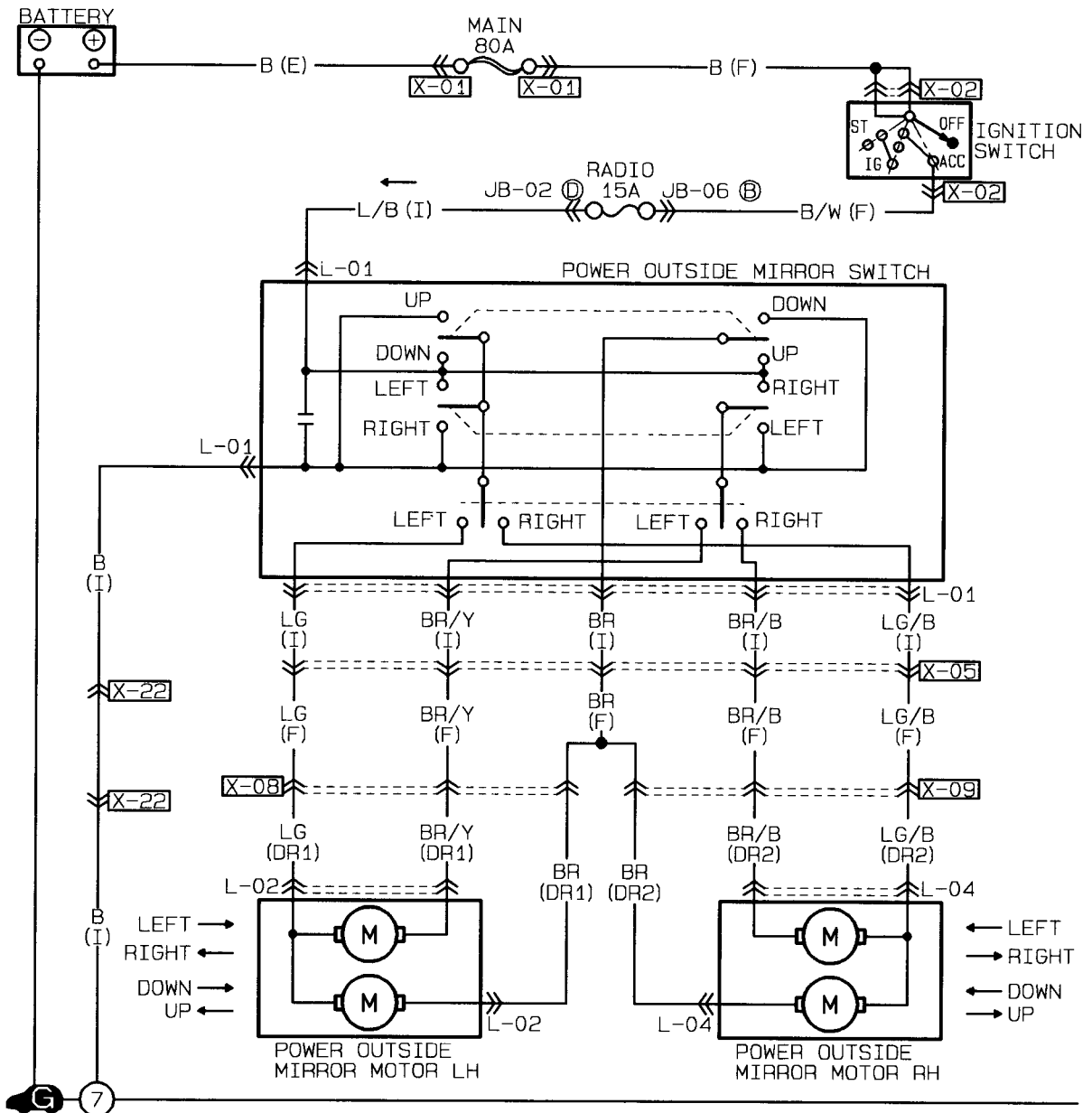

**PROBLEM #3**

The RIGHT MIRROR will NOT adjust LEFT, or RIGHT. However, the RIGHT MIRROR will adjust UP and DOWN. The LEFT MIRROR functions correctly. Trace in GREEN the areas where the problem could be.

**PROBLEM #3**

Both the LEFT AND RIGHT MIRRORS will NOT adjust UP or DOWN. However, both mirrors will adjust LEFT and RIGHT. Trace in BLUE the areas where the problem could be.

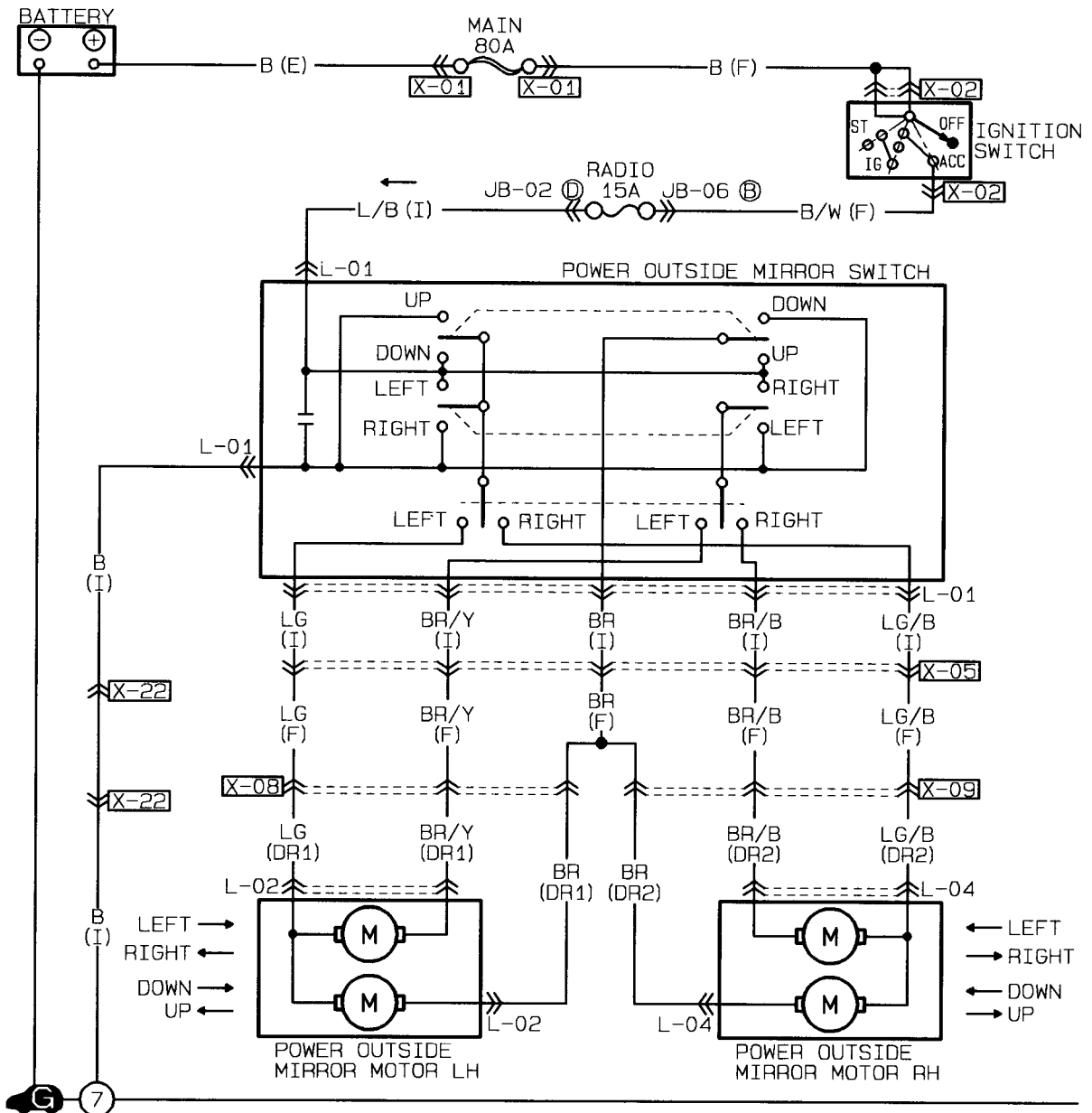

# MAZDA

## Door Lock Worksheets

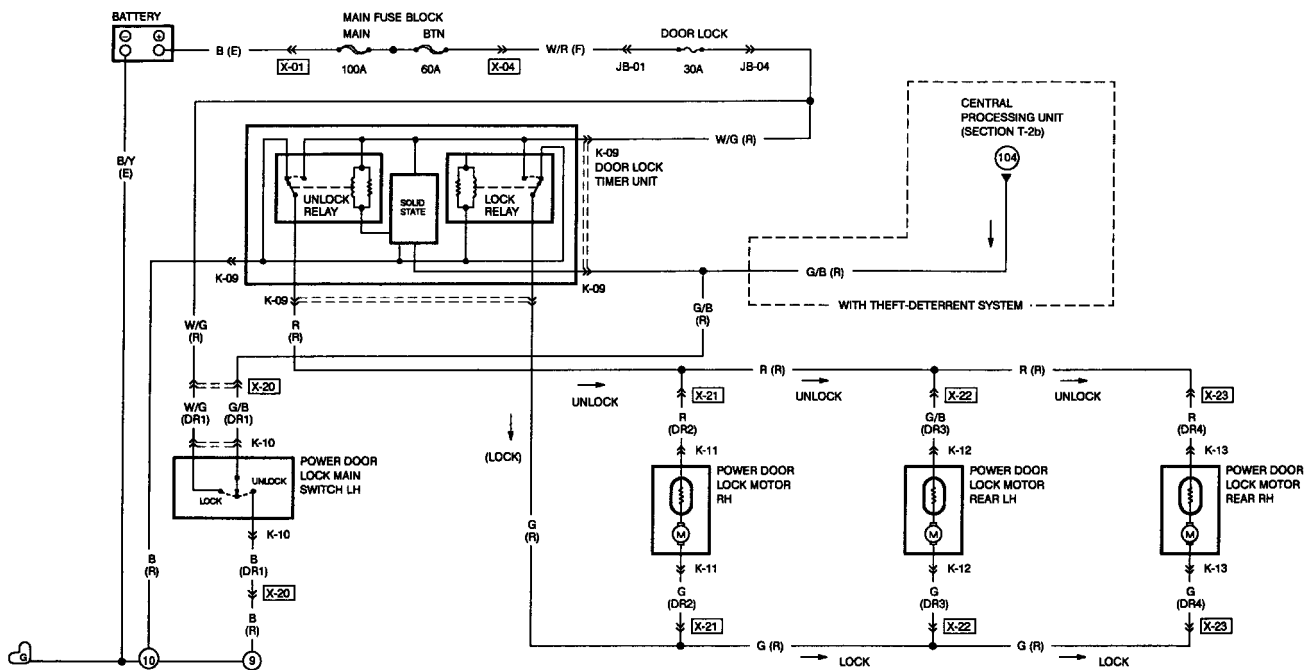

SYSTEM DIAGRAM

B+: Battery positive voltage

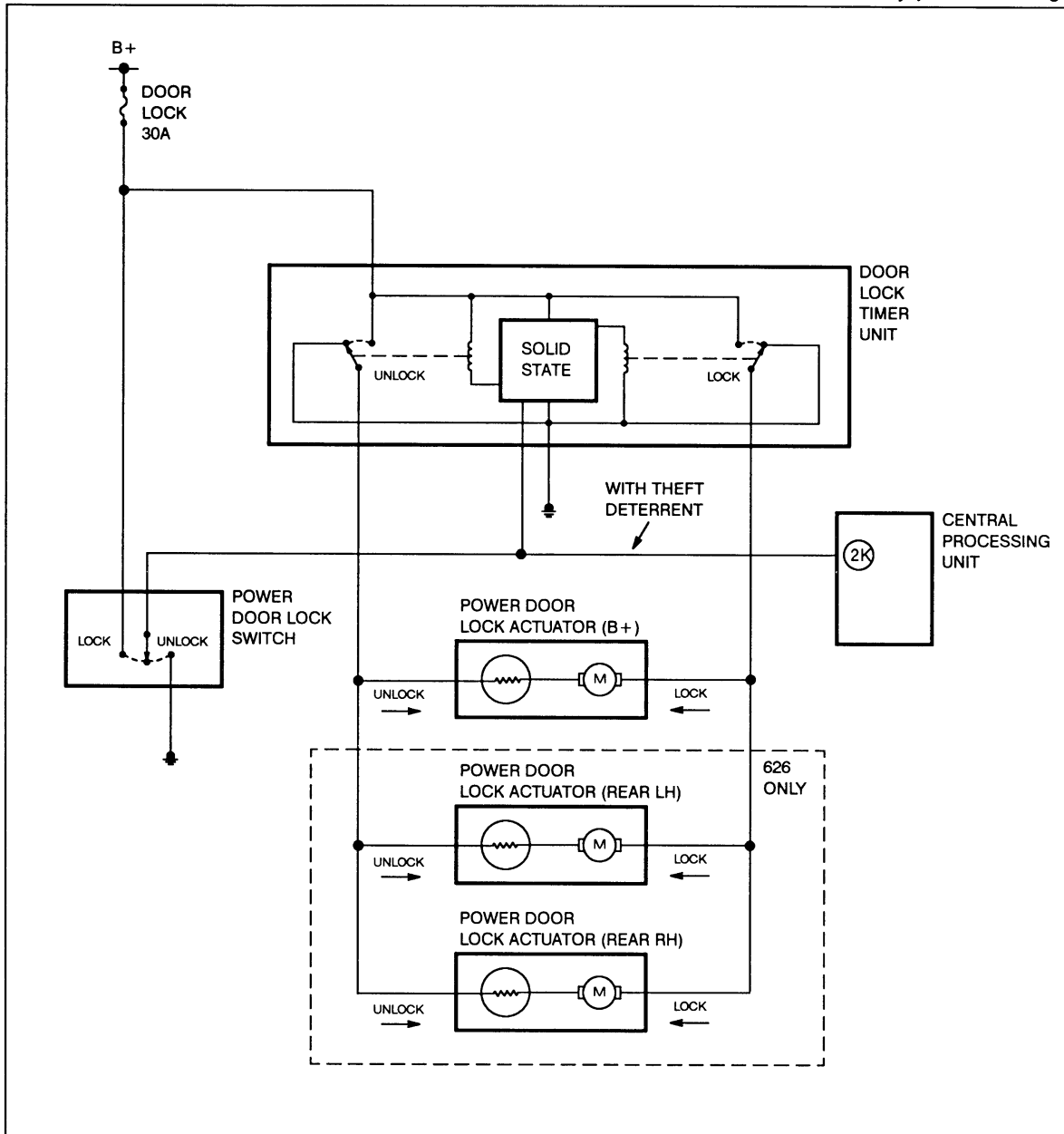

DESCRIPTION

The power door lock system consists of the power door lock switch, the door lock timer unit, and the power door lock actuator(s).

SYSTEM OPERATION

All doors can be centrally locked and unlocked from the driver's door lock knob. The lock knob is mechanically linked to the power door lock switch. When the lock knob is moved to the lock or unlock position, an input signal is sent to the door lock timer unit. The door lock timer unit energizes the proper relay to supply voltage to lock or unlock the doors.



1. Trace in RED the "UNLOCK" INPUT SIGNAL from ground to the Solid Unit inside the Door Lock Timer Control Unit.
2. Trace in ORANGE the "LOCK" INPUT SIGNAL from the battery to the Solid Unit inside the Door Lock Timer Control Unit.
3. Trace in BLUE the POSITIVE B+ circuit from the Battery to the Door Lock Motors in the UNLOCK Position.
4. Trace in GREEN the GROUND circuit from the Door Lock Motors to Ground in the UNLOCK Position.

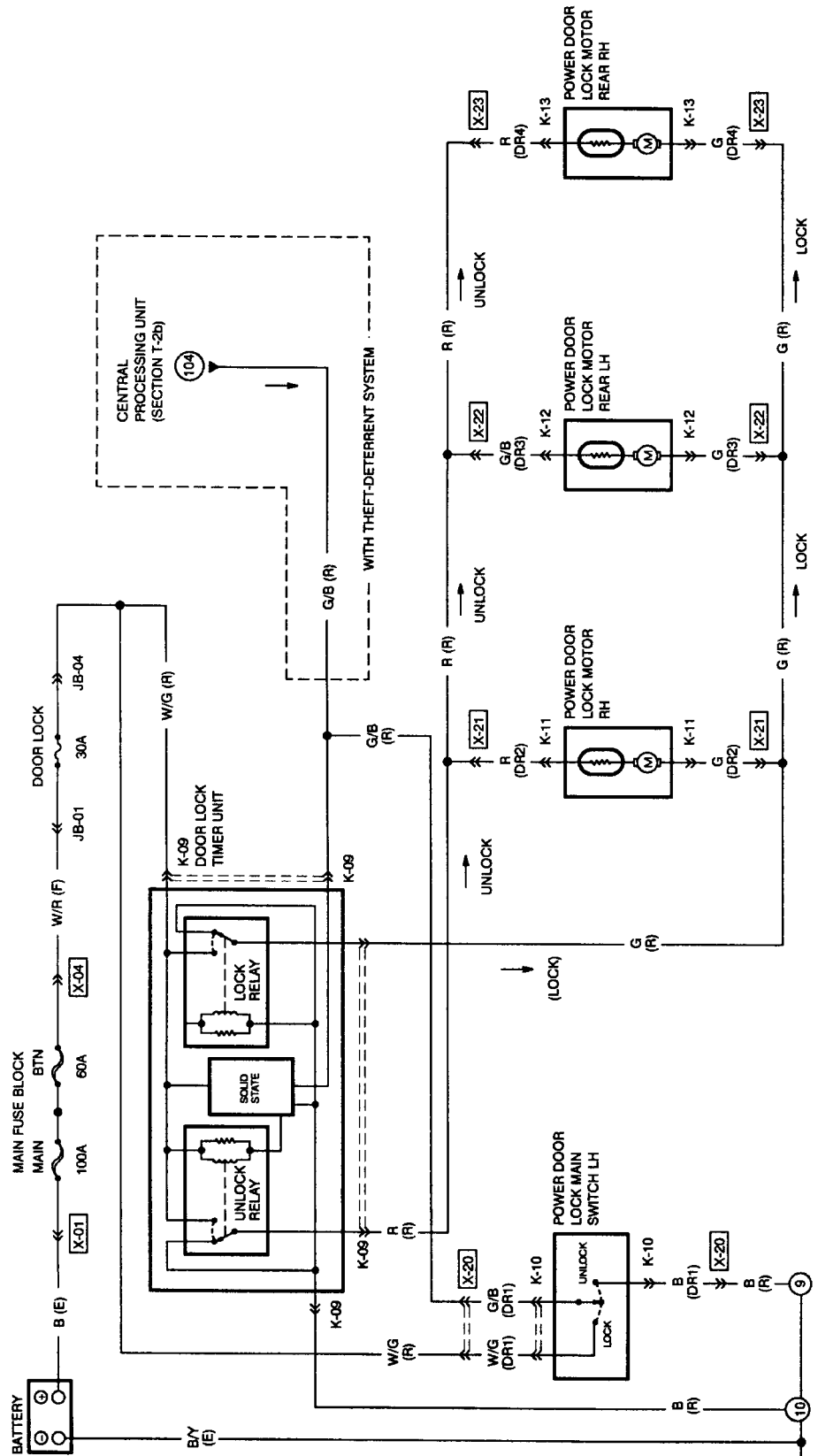

**PROBLEM #1**

Trace in BLUE the area(s) where the problem could be if the Doors will unlock but, **will not lock**.

**PROBLEM #2**

Trace in GREEN the area(s) where the problem could be if **both Rear Doors will not lock or unlock**. All the door locks function correctly.

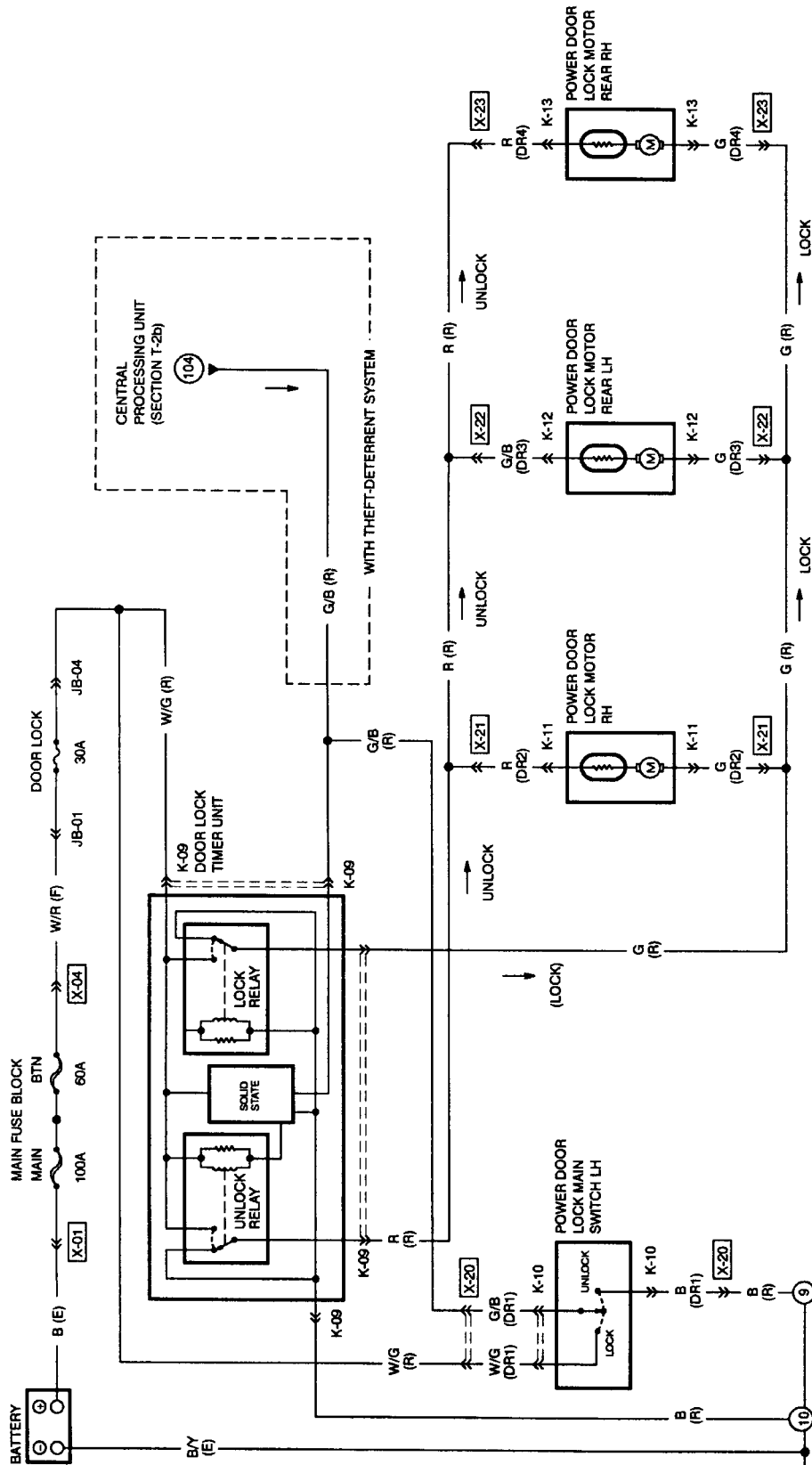

**PROBLEM #1**

Trace in BLUE the area(s) where the problem could be if the Door will lock the doors but **not unlock**.

**PROBLEM #2**

Trace in RED the area(s) where the problem could be if **all the Doors will not lock or unlock**.

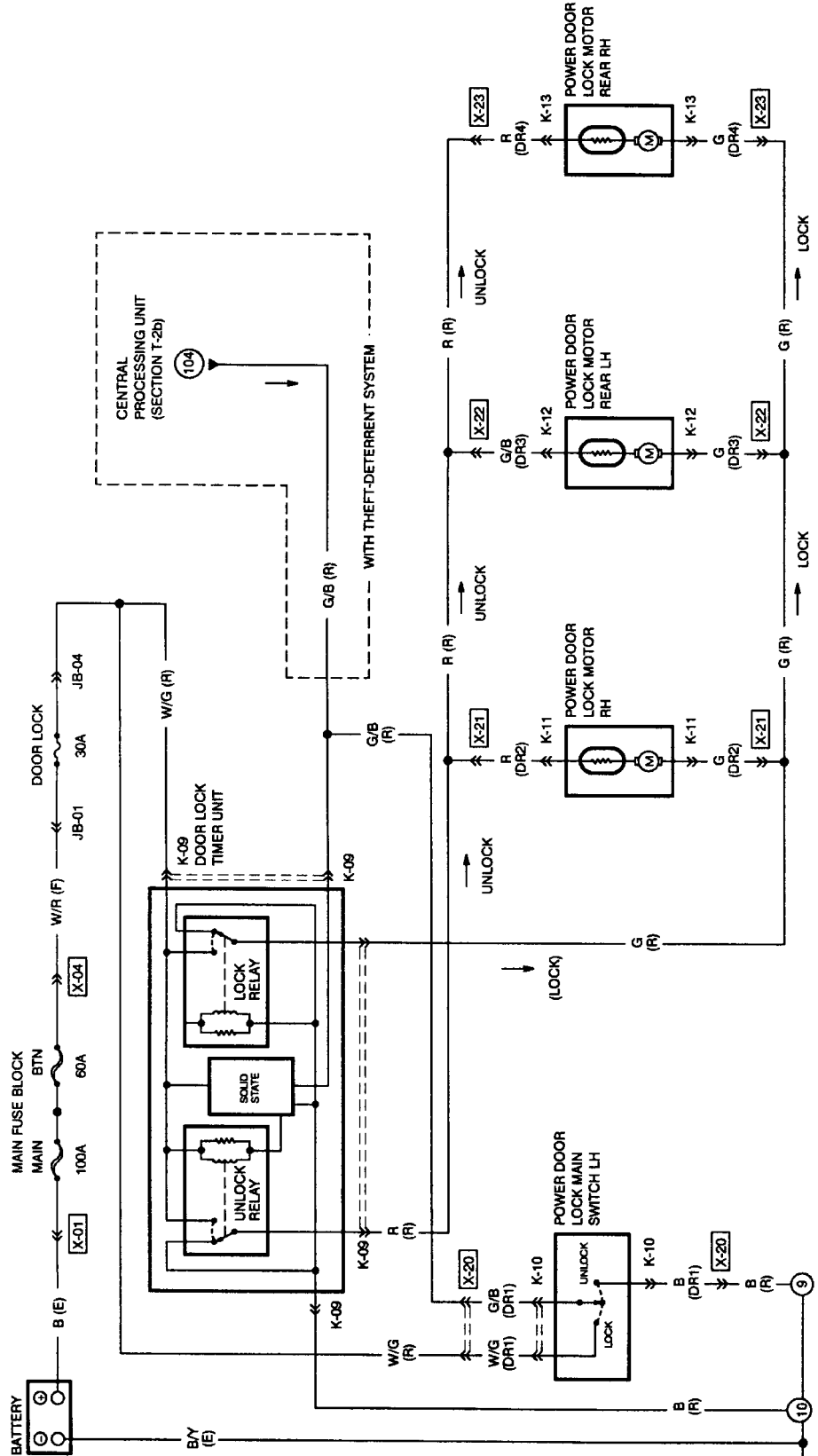

Determine what the affect will be on the following circuit.

1. How will the circuit be affected if there is an open at point T.
2. How will the circuit be affected if there is an open at point U.
3. How will the circuit be affected if there is an open at point V.
4. How will the circuit be affected if there is an open at point W.
5. How will the circuit be affected if there is an open at point X.
6. How will the circuit be affected if there is an open at point Y.
7. How will the circuit be affected if there is an open at point Z.

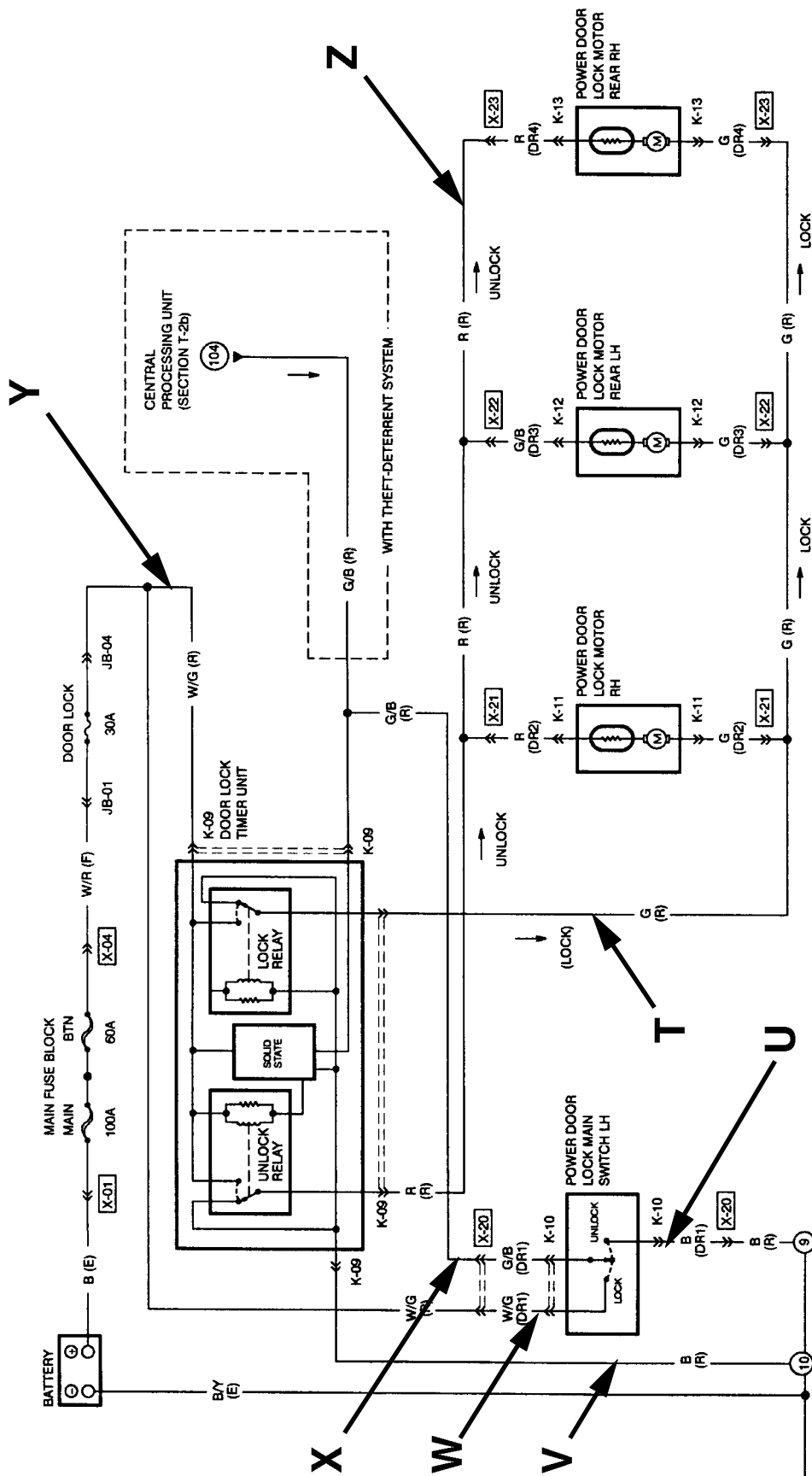

# MAZDA

## Cig Lighter/Clock/ and Defogger

# Worksheets

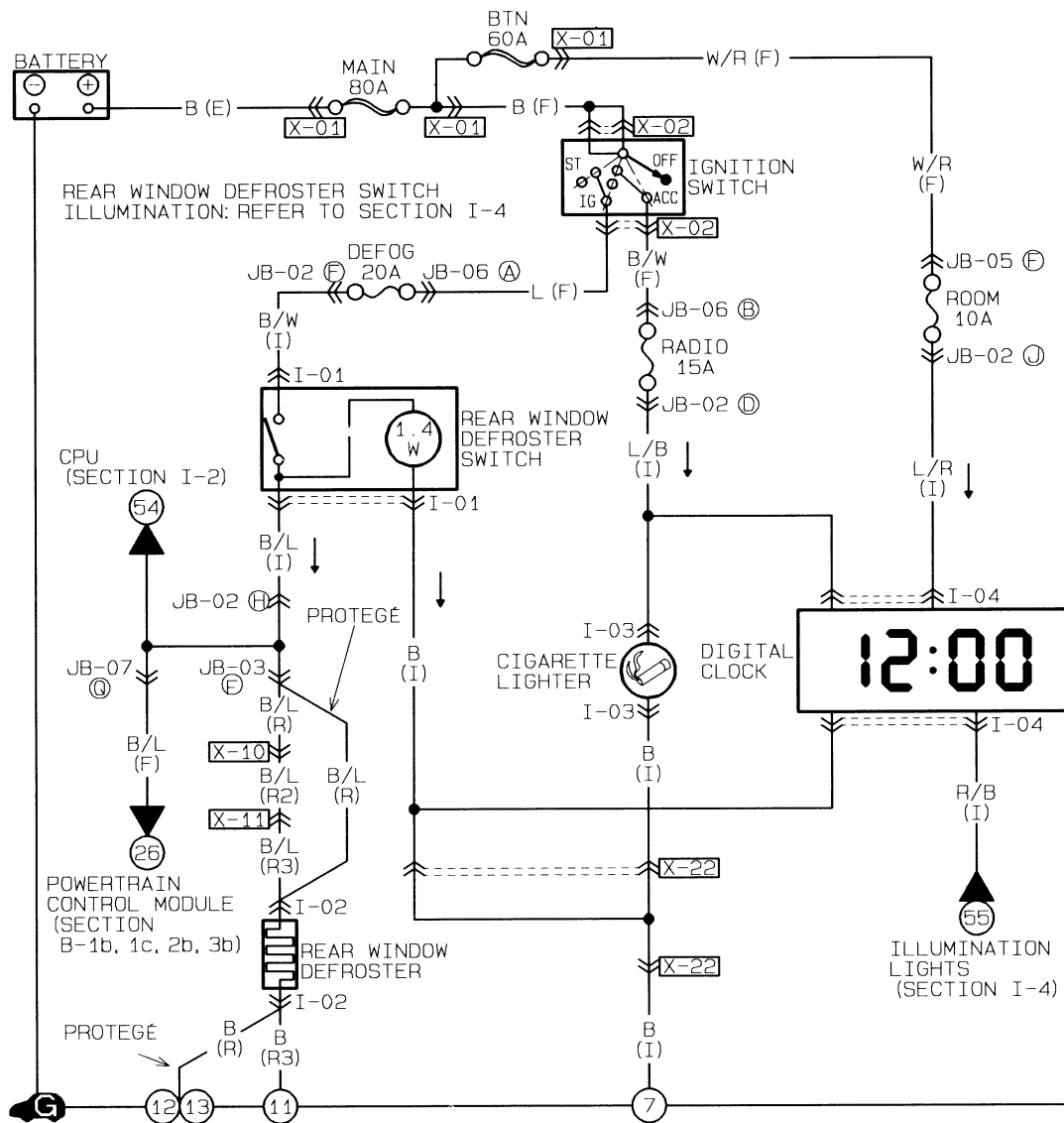

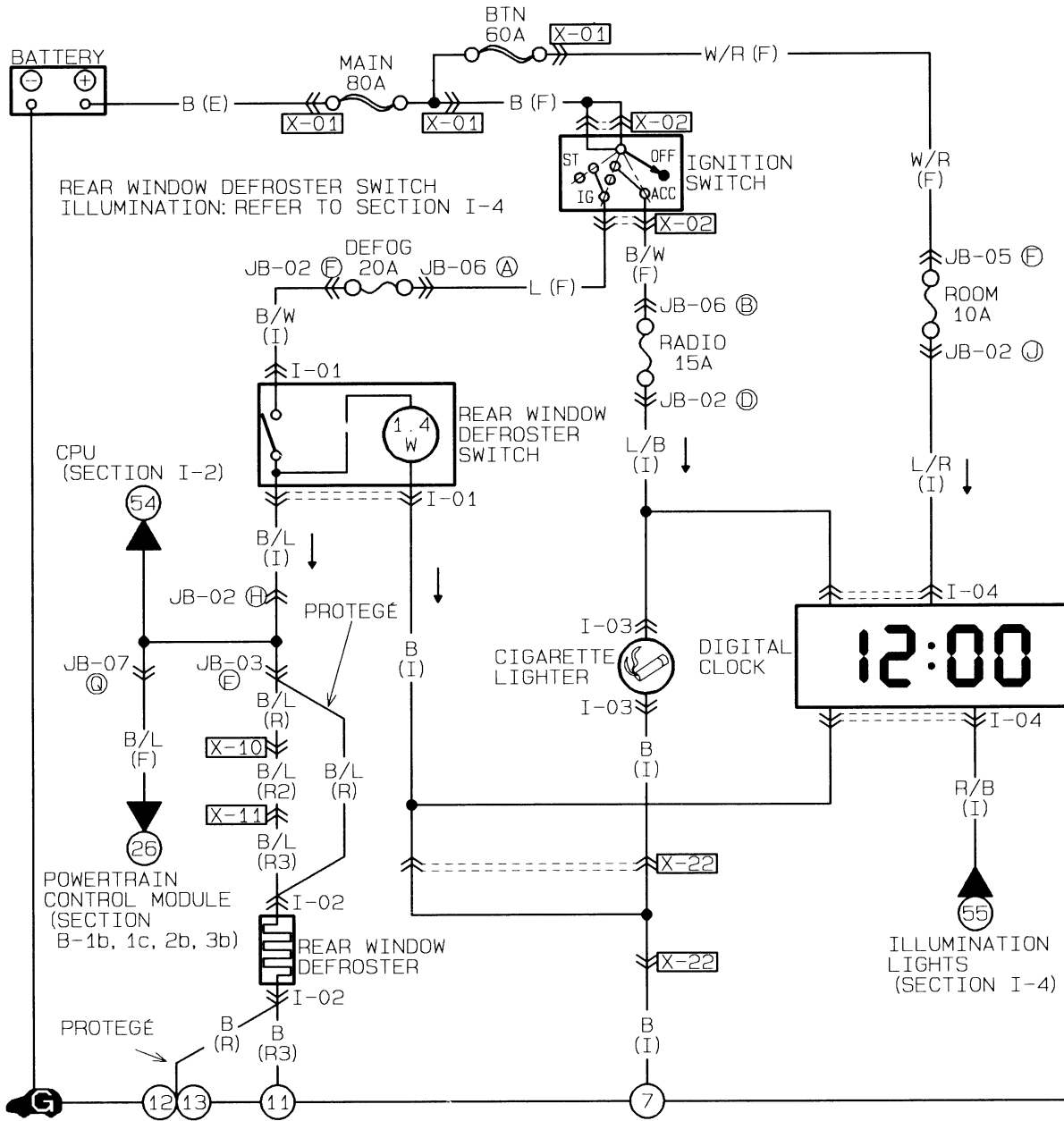

1. Trace in RED the part of the clock's circuit that allows the clock's display to light.
2. Trace in BLUE the part of the clock's circuit that allows the Clock to keep the correct time when the engine is not running (Memory).
3. Trace in GREEN the part of the clock's circuit that allows the Clock's display to dim when the headlights are on.

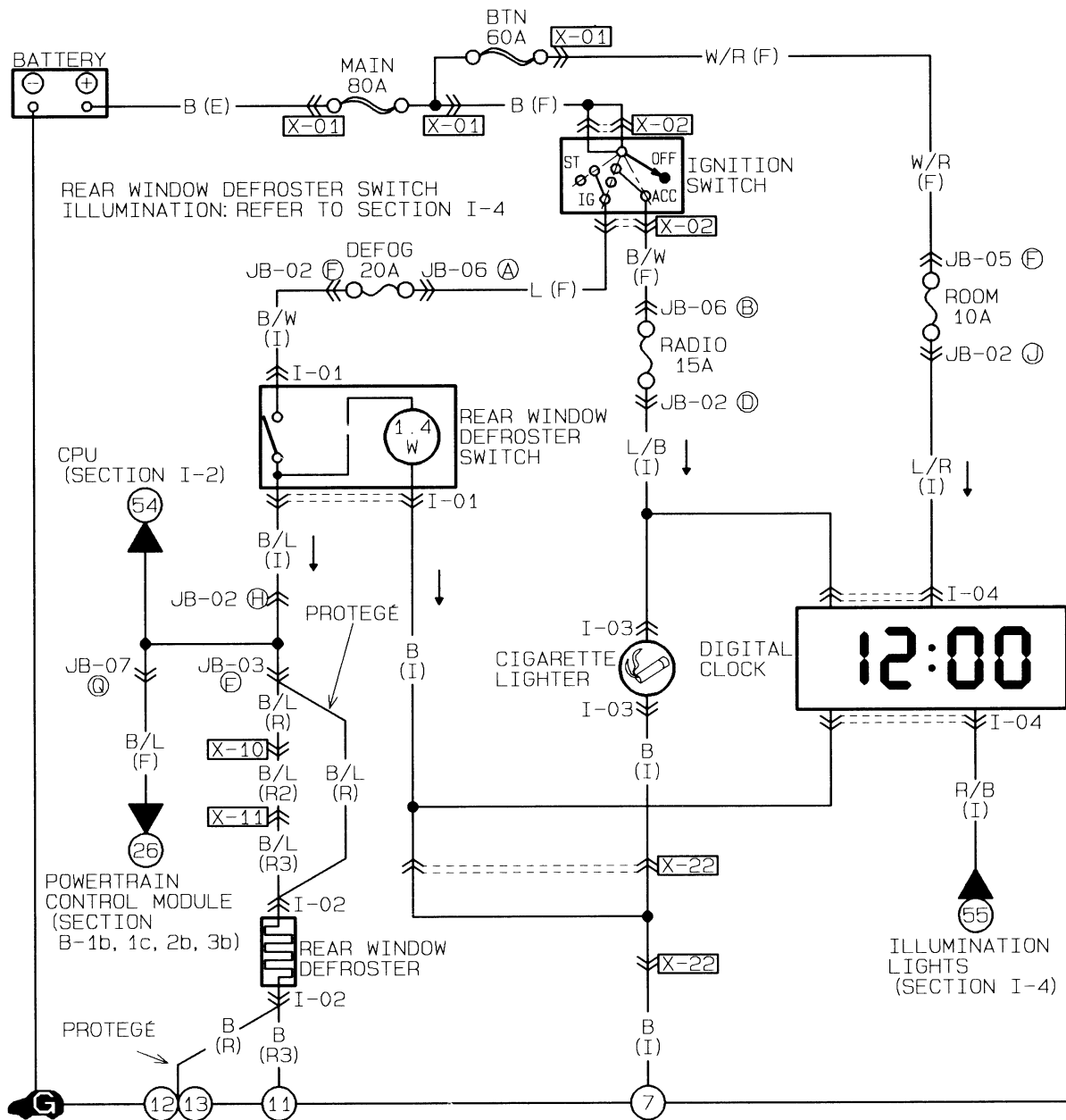

1. Draw in RED the DEFOGGER circuit from the battery to ground.
2. Draw in BLUE the DEFOGGER LAMP circuit from the battery to ground.

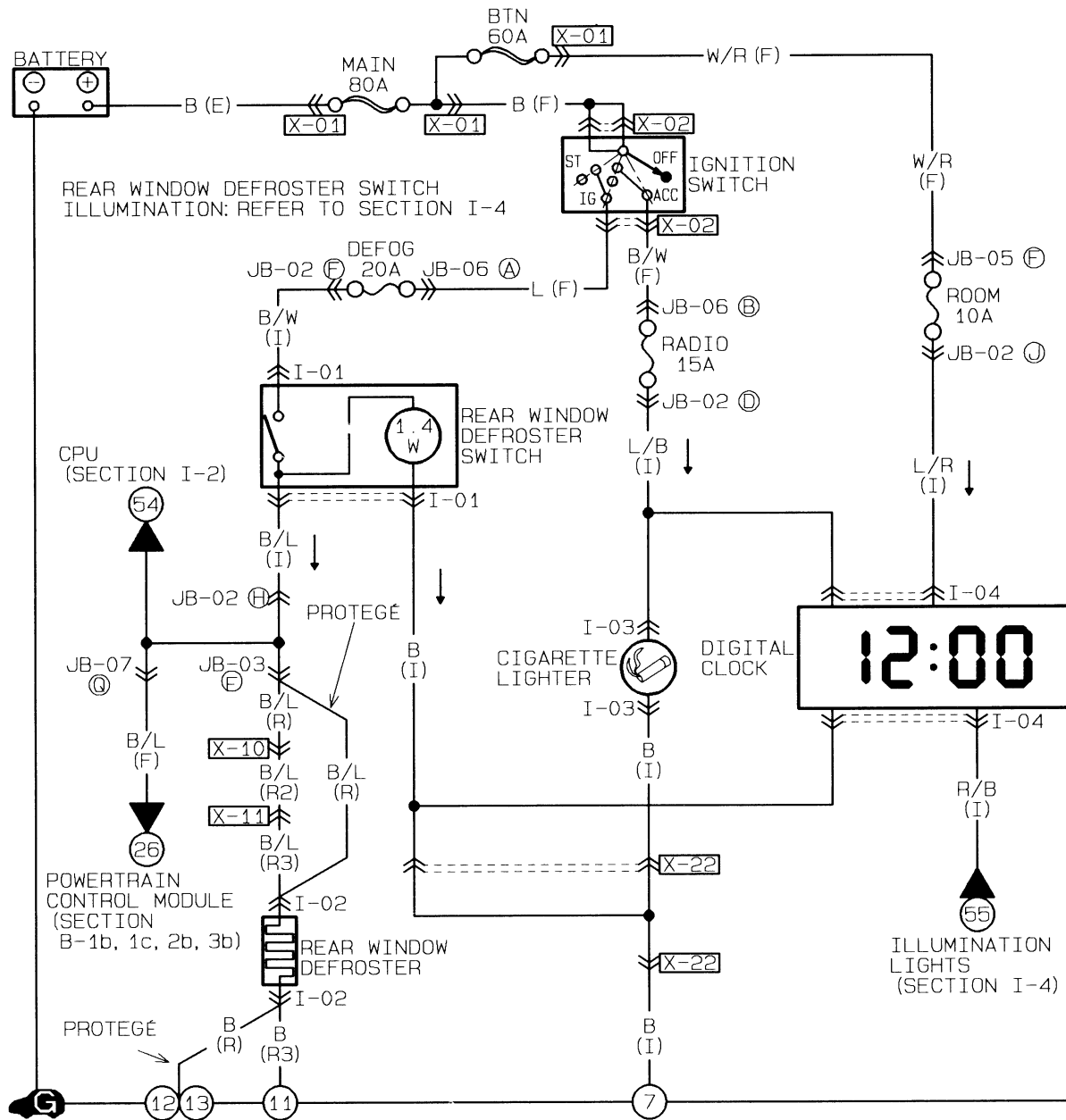

**Note Ignition switch is in the run position**

1. With the Defogger Switch in the OFF position, what voltage would you expect to find at point **U, V, W, & Z** ?
2. With the Defogger Switch in the ON position, what voltage would you expect to find at point **U, V, W, & Z** ?
3. With the Headlight Switch in the ON position, what voltage would you expect to find at point **W, X, Y, & Z** ?

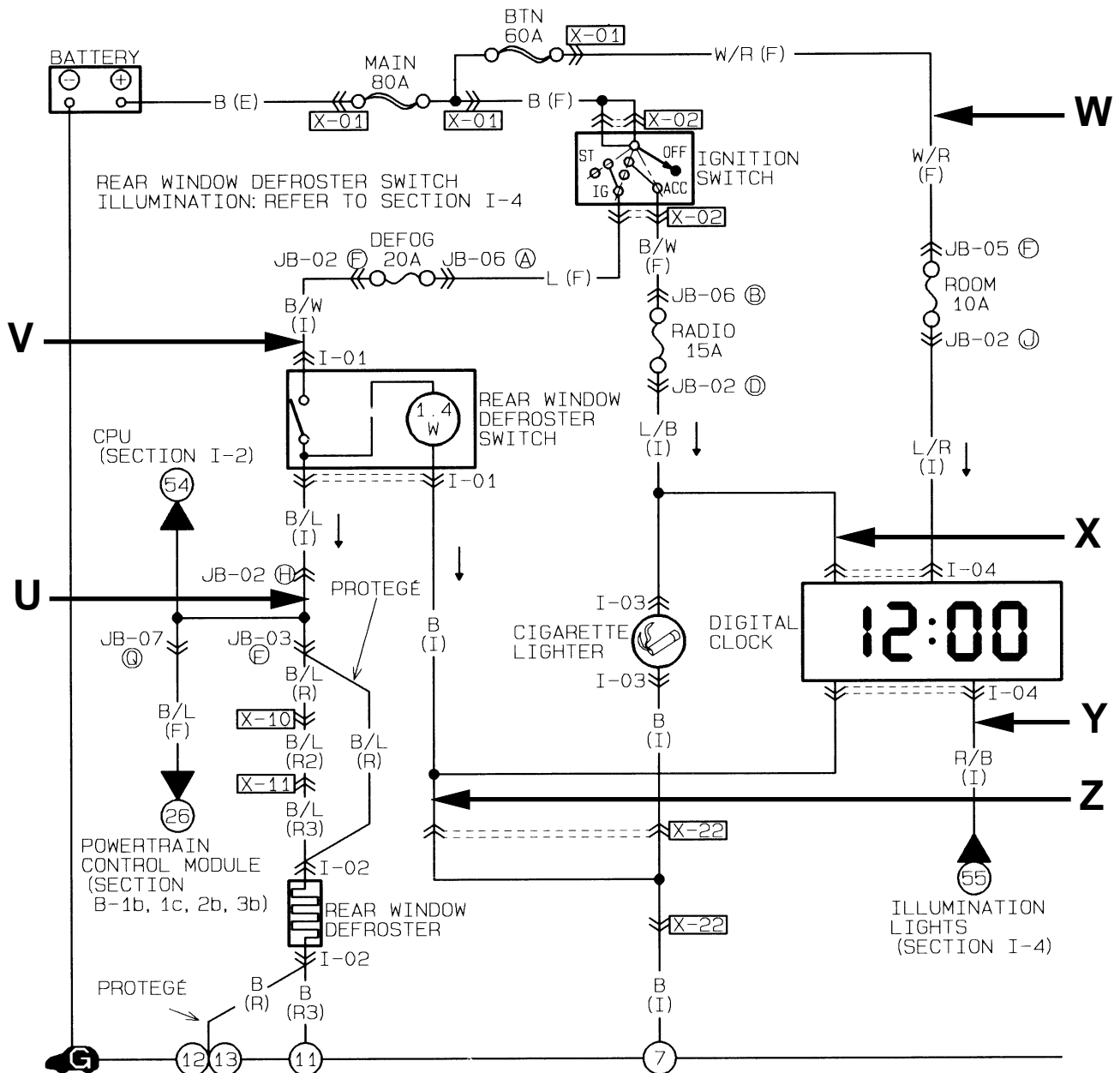

Determine what the affect will be on the following circuit.

1. How will the circuit be affected if there is an open at point **V**.
2. How will the circuit be affected if there is an open at point **W**.
3. How will the circuit be affected if there is an open at point **X**.
4. How will the circuit be affected if there is an open at point **Y**.
5. How will the circuit be affected if there is an open at point **Z**.

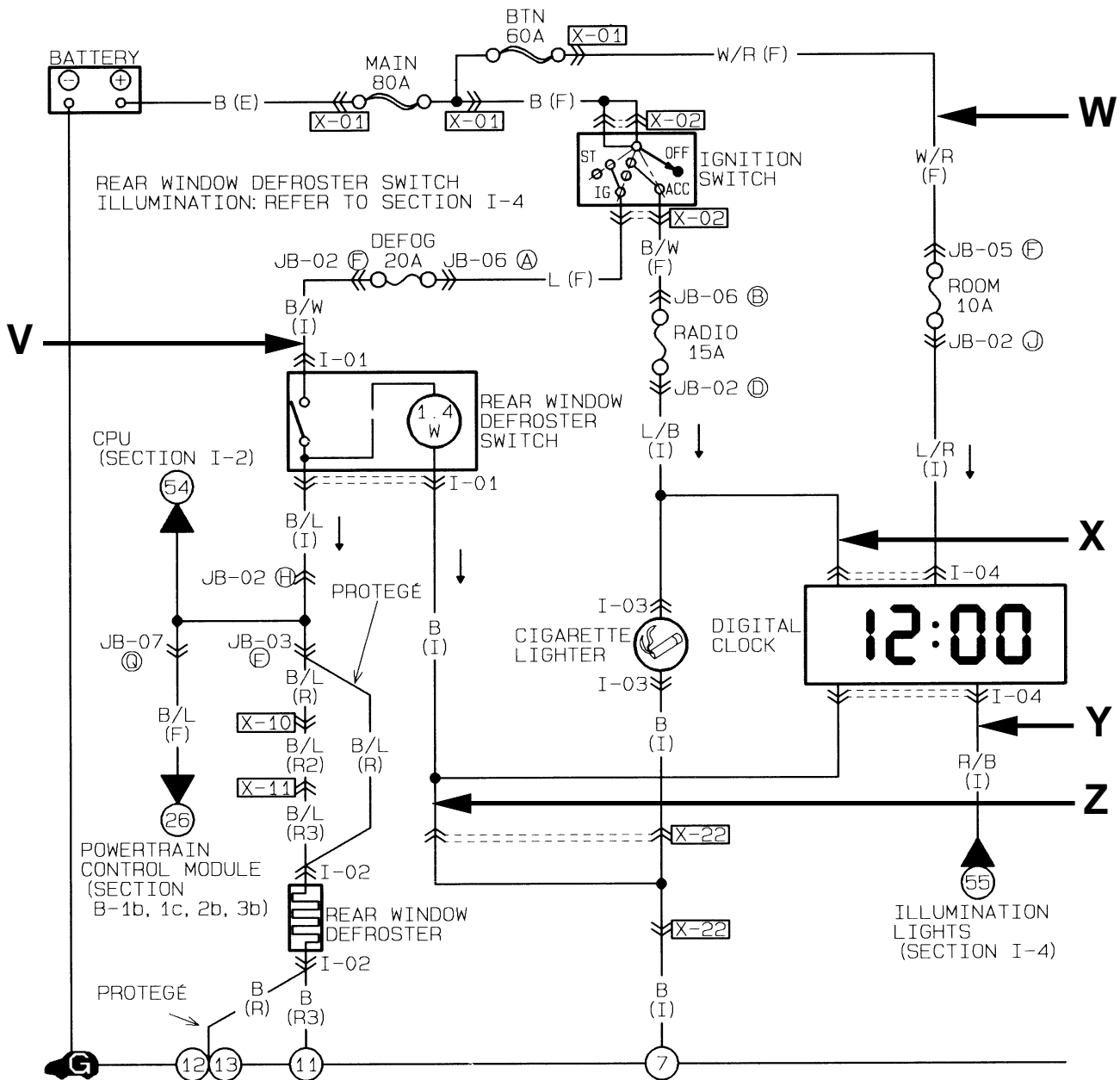

1. The clock display will not dim when the headlamps are turned on.  
Trace in RED the area(s) that could be at fault.
2. The clock loses its time (memory) each time the ignition switch is turned off and has to be reset with the correct time.  
Trace in BLUE the area(s) that could be at fault.
3. The clock display never light up. The cigarette lighter works.  
Trace in GREEN the area(s) that could be at fault.

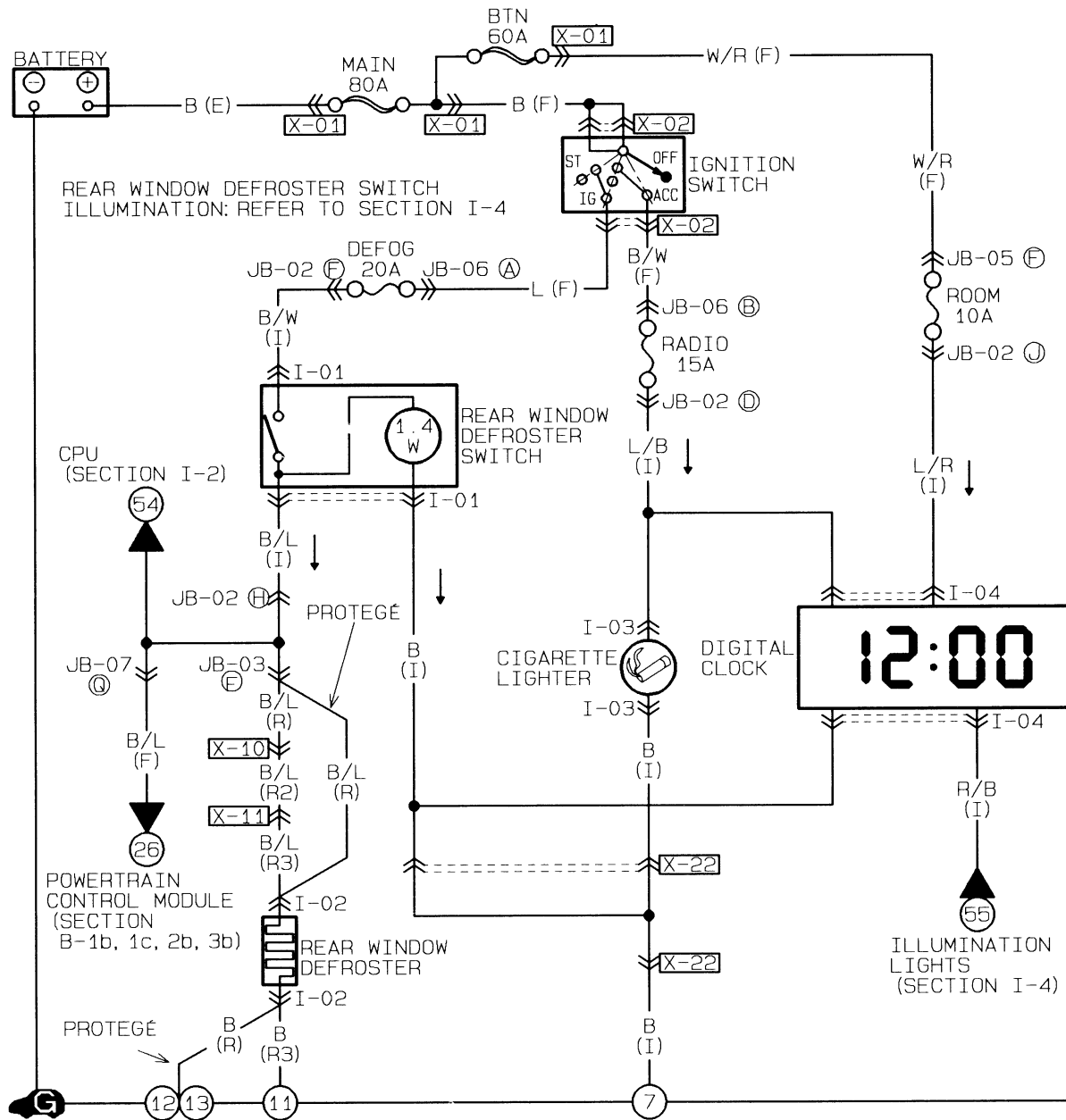

1. The rear window defroster switch lights up, but the rear window defroster does not work. Trace in BLUE the area(s) that could be at fault.
2. The rear window defroster does not work. The defroster switch light does not light. Trace in GREEN the area(s) that could be at fault.

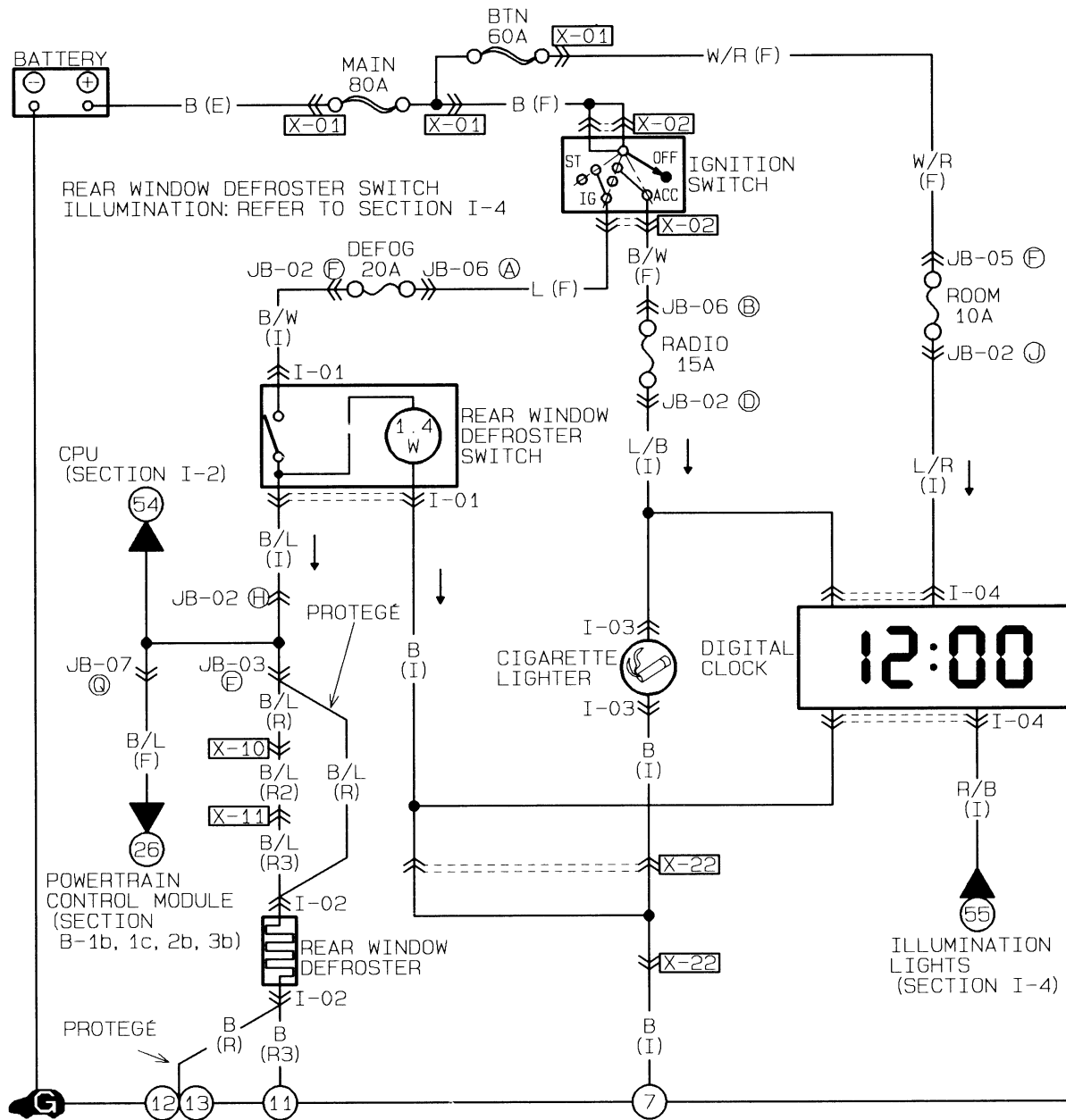

# MAZDA

## Wiper/Washer

### Worksheets

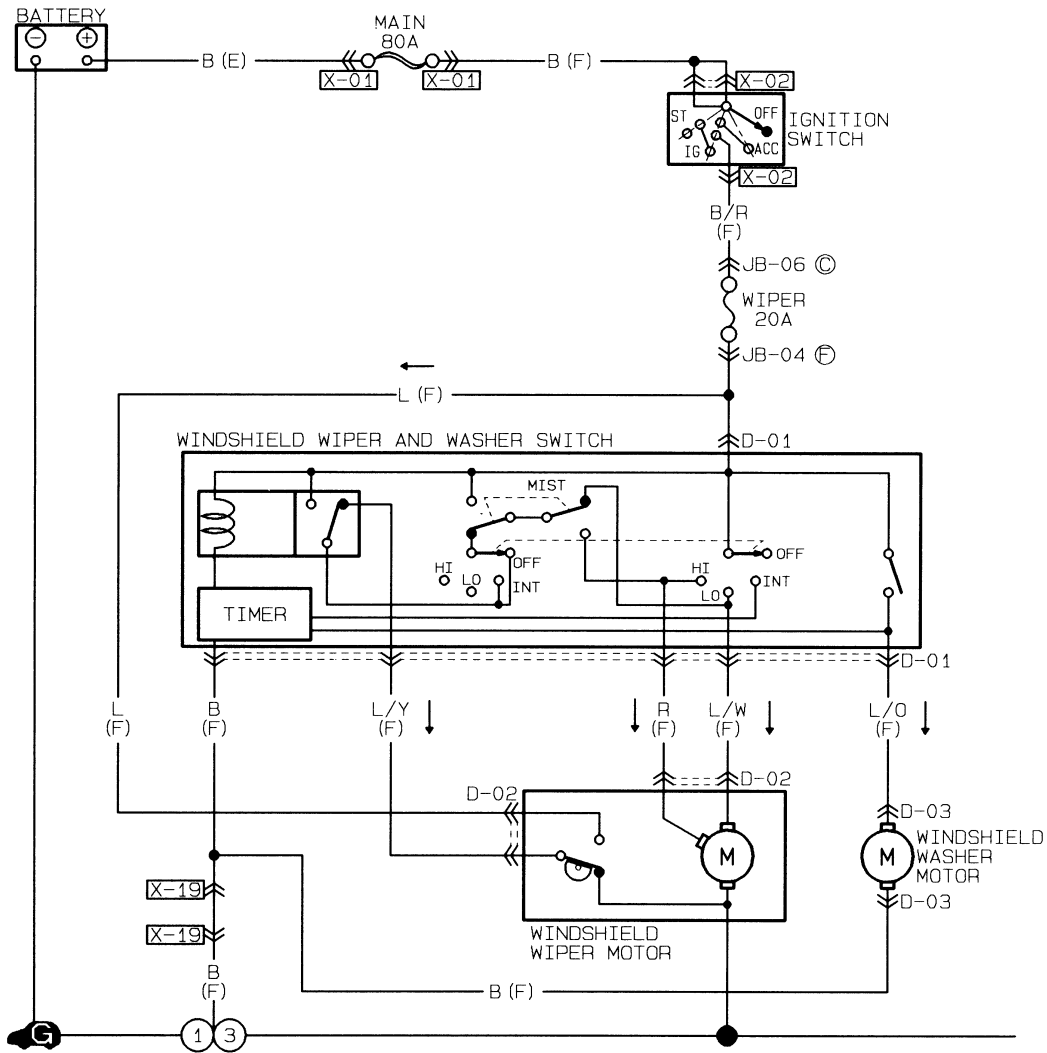

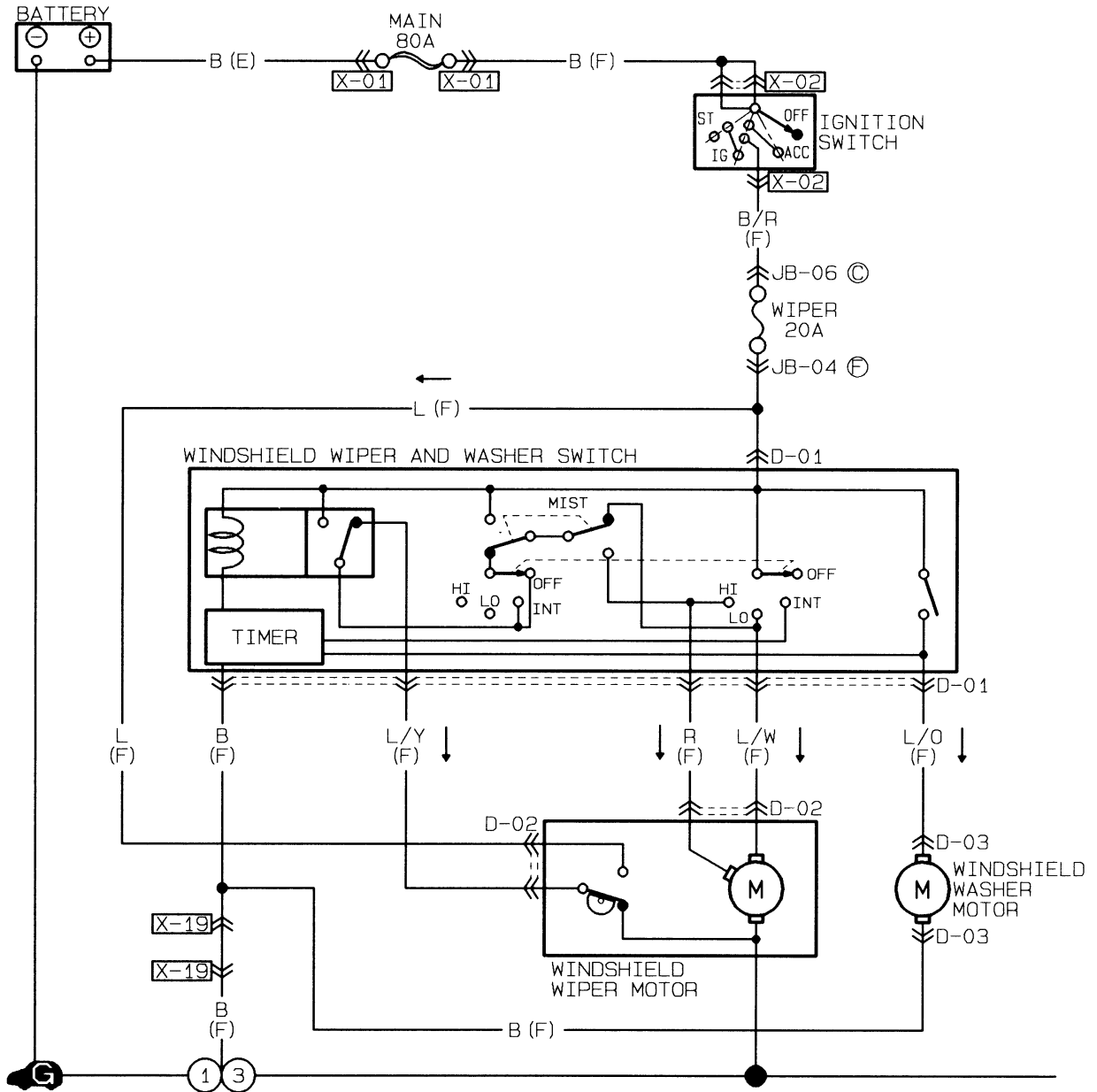

The WIPER SWITCH is in the LOW SPEED position.

1. Trace in RED the POSITIVE power flow from the battery to the wiper motor.
2. Trace in BLUE the NEGATIVE power flow from the wiper motor to ground.

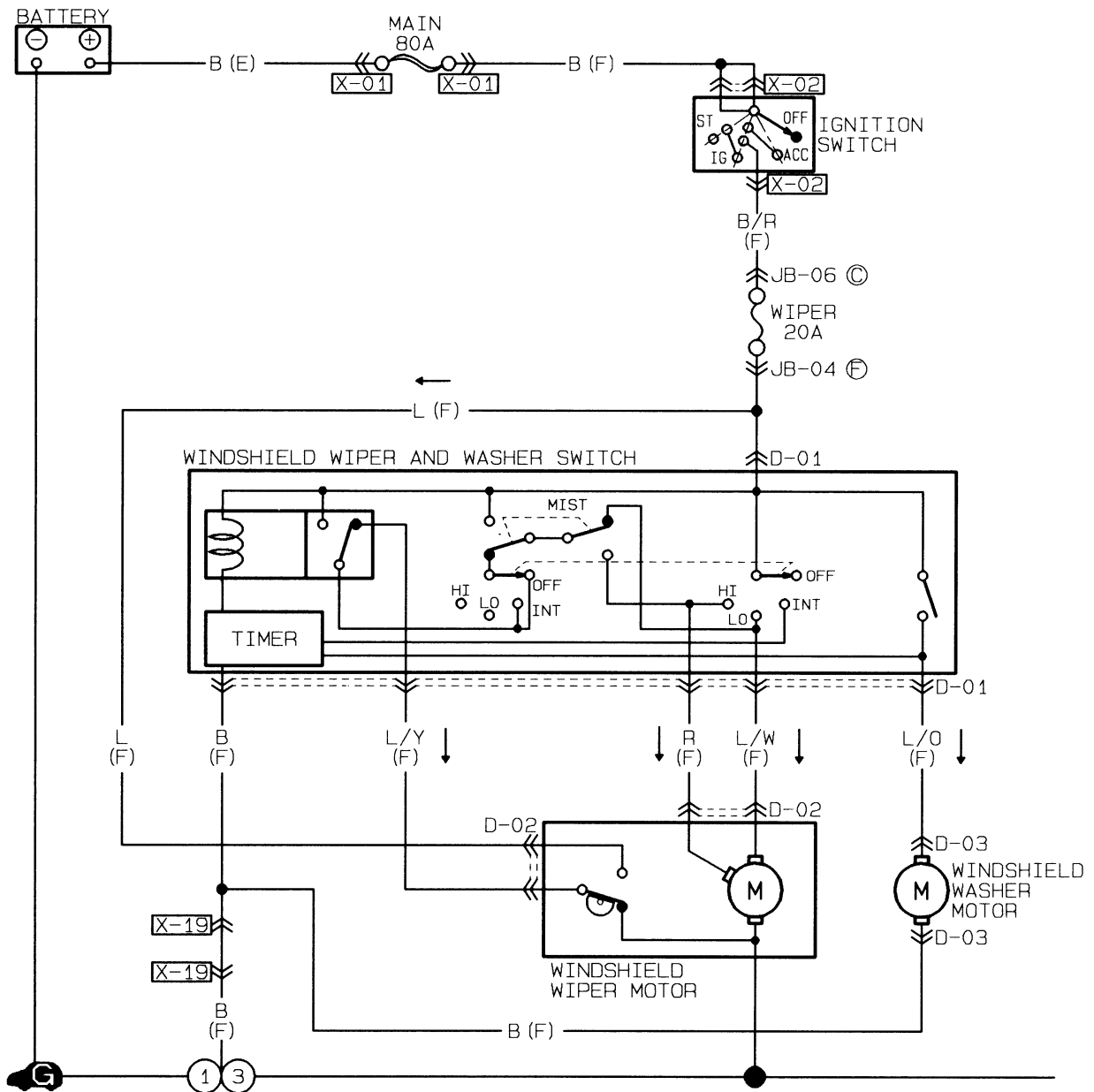

With the WIPER SWITCH is in the HIGH SPEED position.

1. Trace in RED the POSITIVE power flow from the battery to the wiper motor.
2. Trace in BLUE the NEGATIVE power flow from the wiper motor to ground.

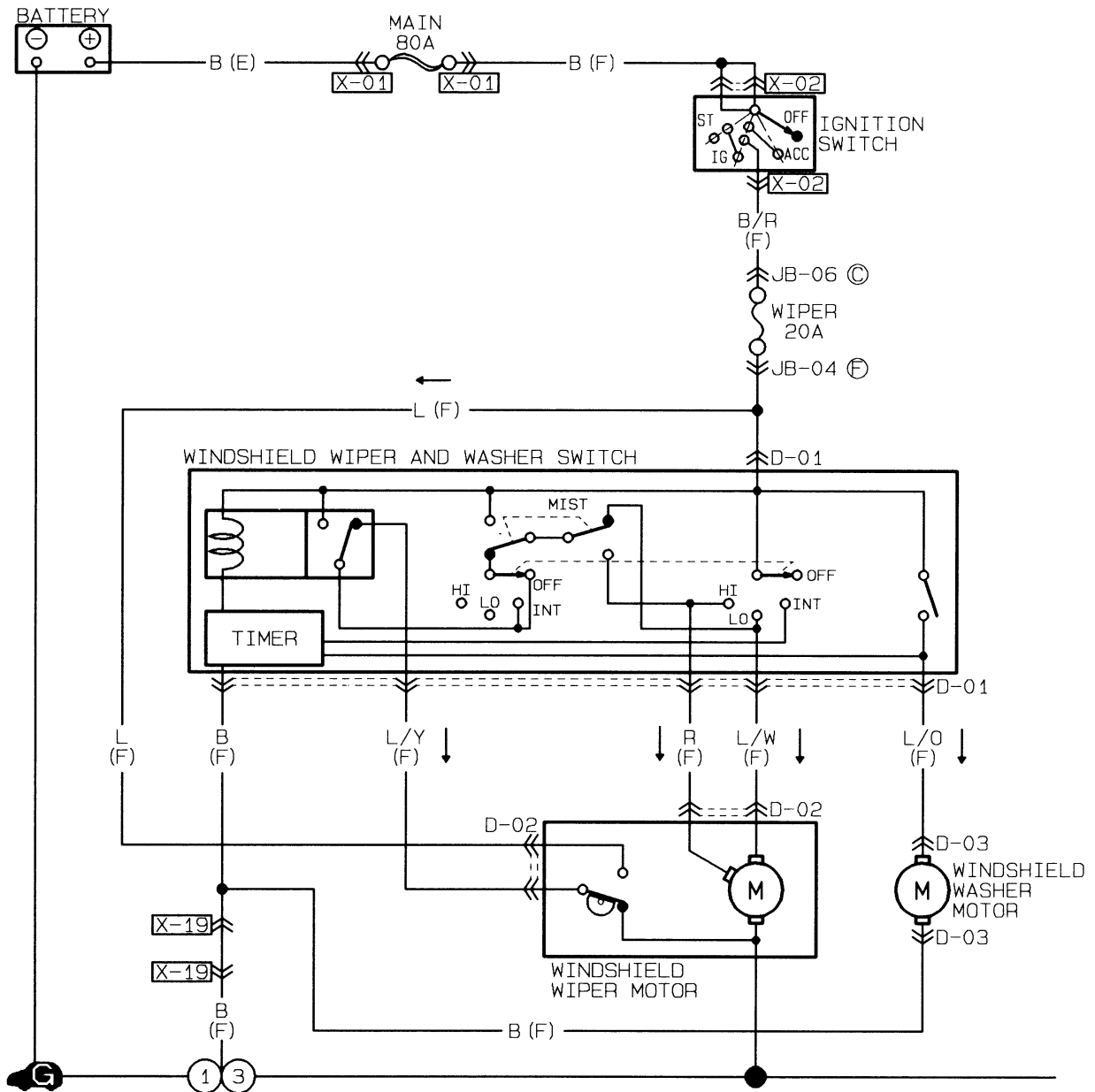

After the WIPER SWITCH has been turned off with the wipers in the up position. The wipers return to the park position. Identify and draw this circuit .

1. Trace in RED the POSITIVE power flow from the battery to the wiper motor.
2. Trace in BLUE the NEGATIVE power flow from the wiper motor to ground.

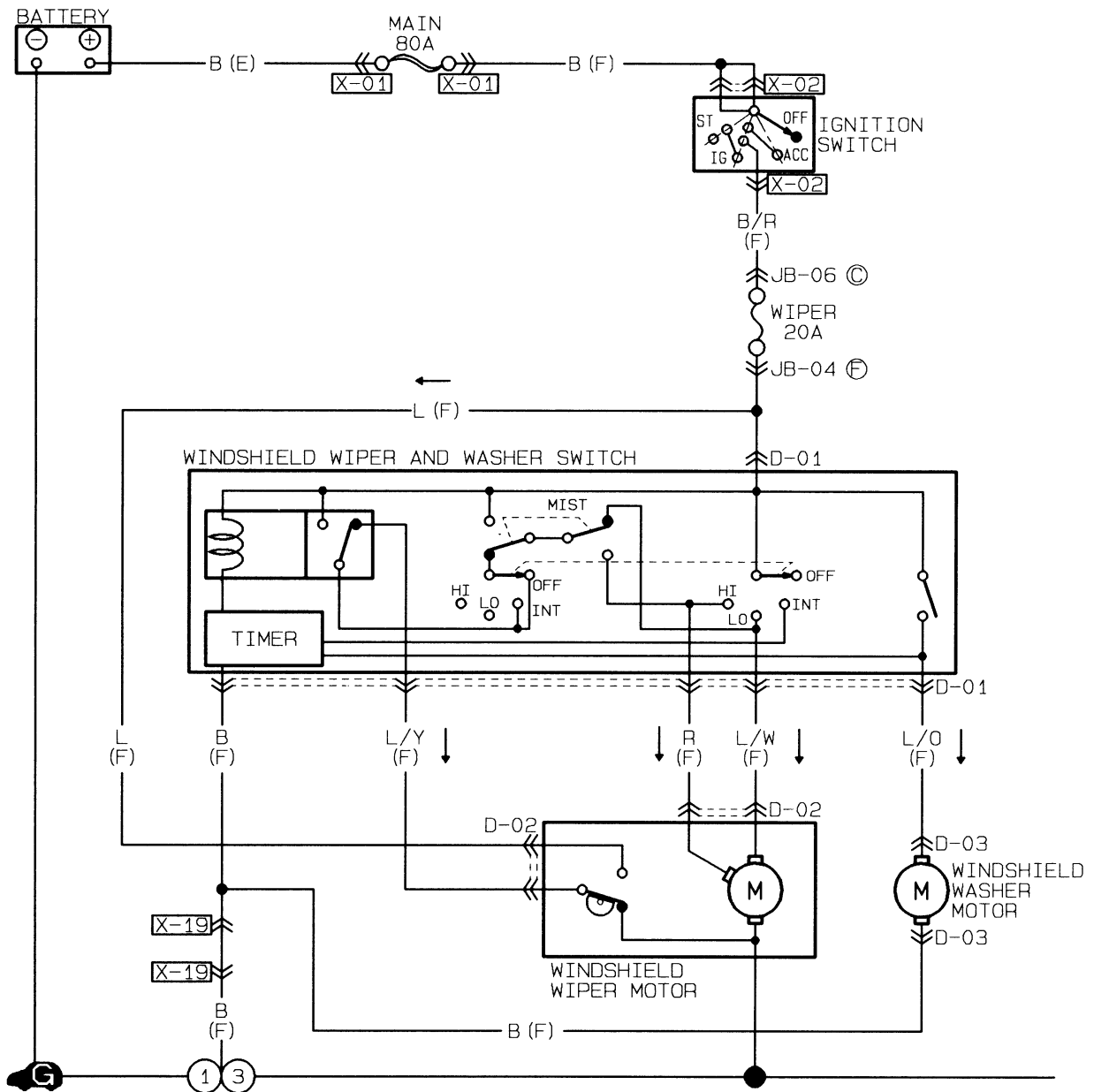

After the WIPER SWITCH has been turned to the INTERMITTENT position. The wipers work intermittently using a timer. Identify and draw this circuit .

1. Trace in RED the POSITIVE INPUT power flow from the battery to the timer.
2. Trace in BLUE the NEGATIVE power flow from the timer to ground.
3. Trace in ORANGE the TIMER OUTPUT Ground Wire from the timer to the COIL.
4. Trace in GREEN the INTERMITTENT WIPER CIRCUIT from the batter to the motor.

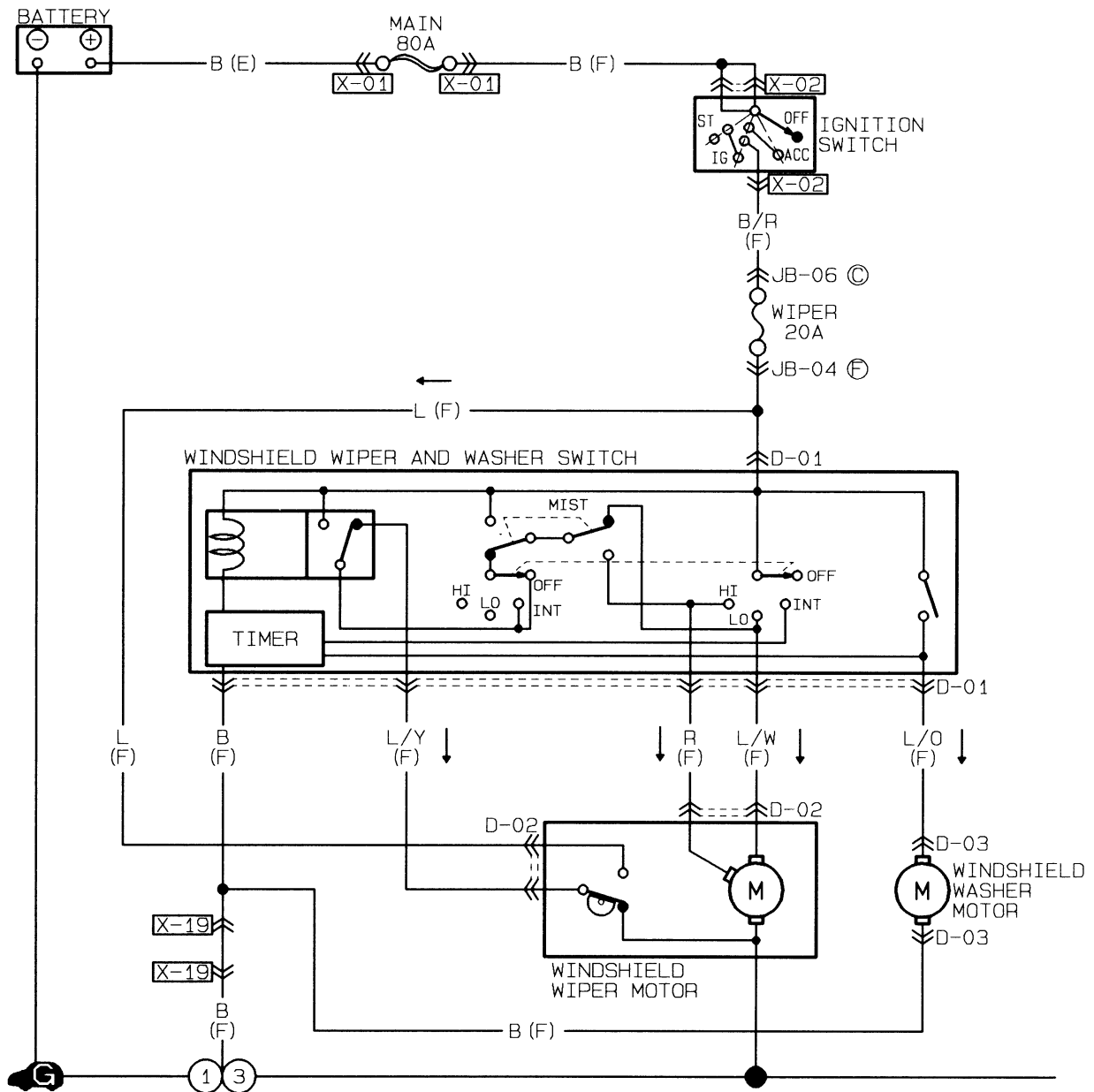

1. How will the circuit be affected if there is an open at point **V**?
2. How will the circuit be affected if there is an open at point **W**?
3. How will the circuit be affected if there is an open at point **X**?
4. How will the circuit be affected if there is an open at point **Y**?
5. How will the circuit be affected if there is an open at point **Z**?

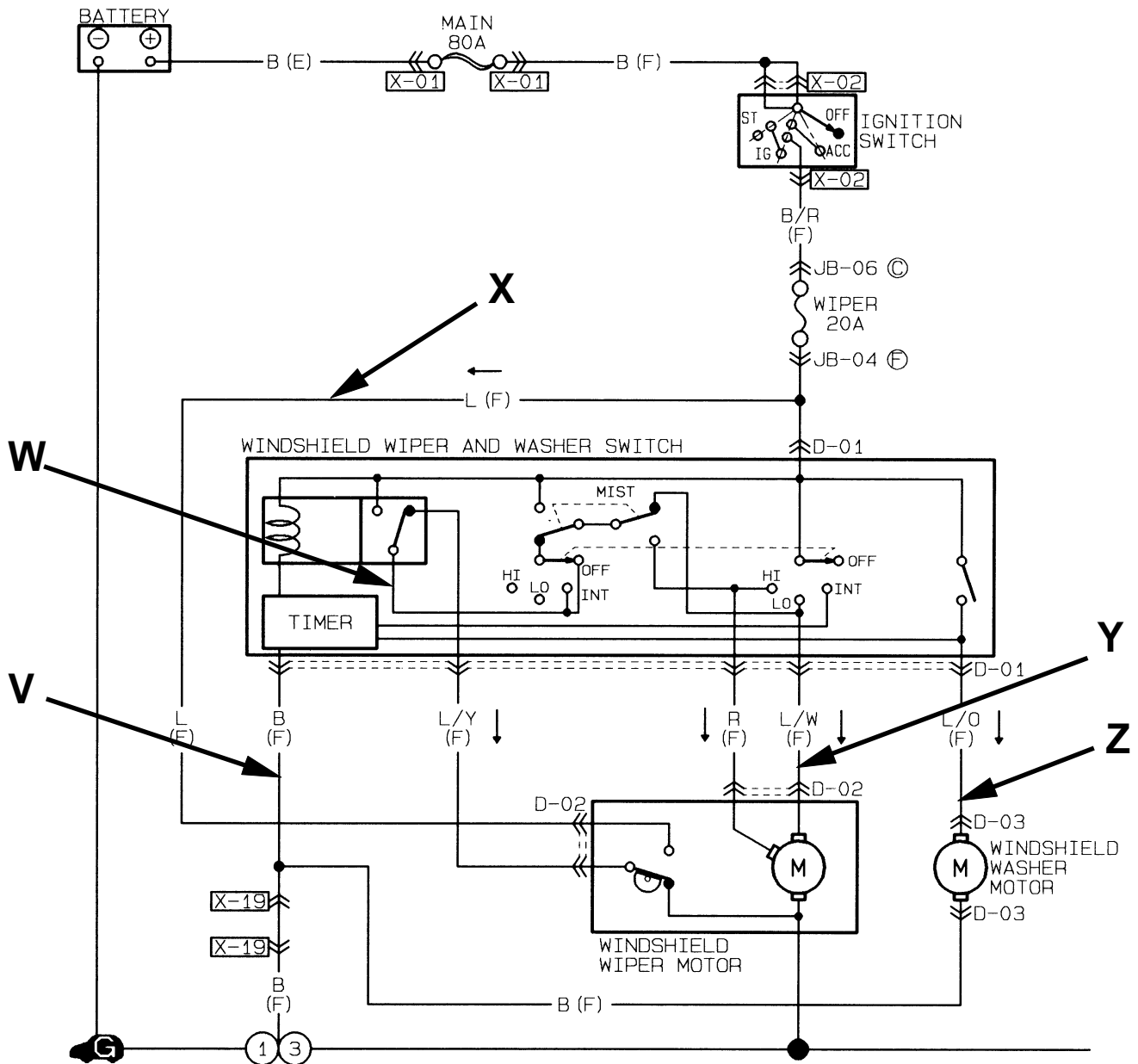

1. The wipers will not work in the HIGH SPEED position. All other positions function correctly. Trace in RED the area(s) that could be at fault.
2. The wipers stay up on the windshield when the wiper switch is turned off. All other wiper functions work correctly (high, low, mist, etc.). Trace in BLUE the area(s) that could be at fault.
3. The wipers will not operate (pulse) when the windshield washer switch is pushed. The washer works. The wipers will work when put in HI or LOW speed positions. Trace in GREEN the area(s) that could be at fault.

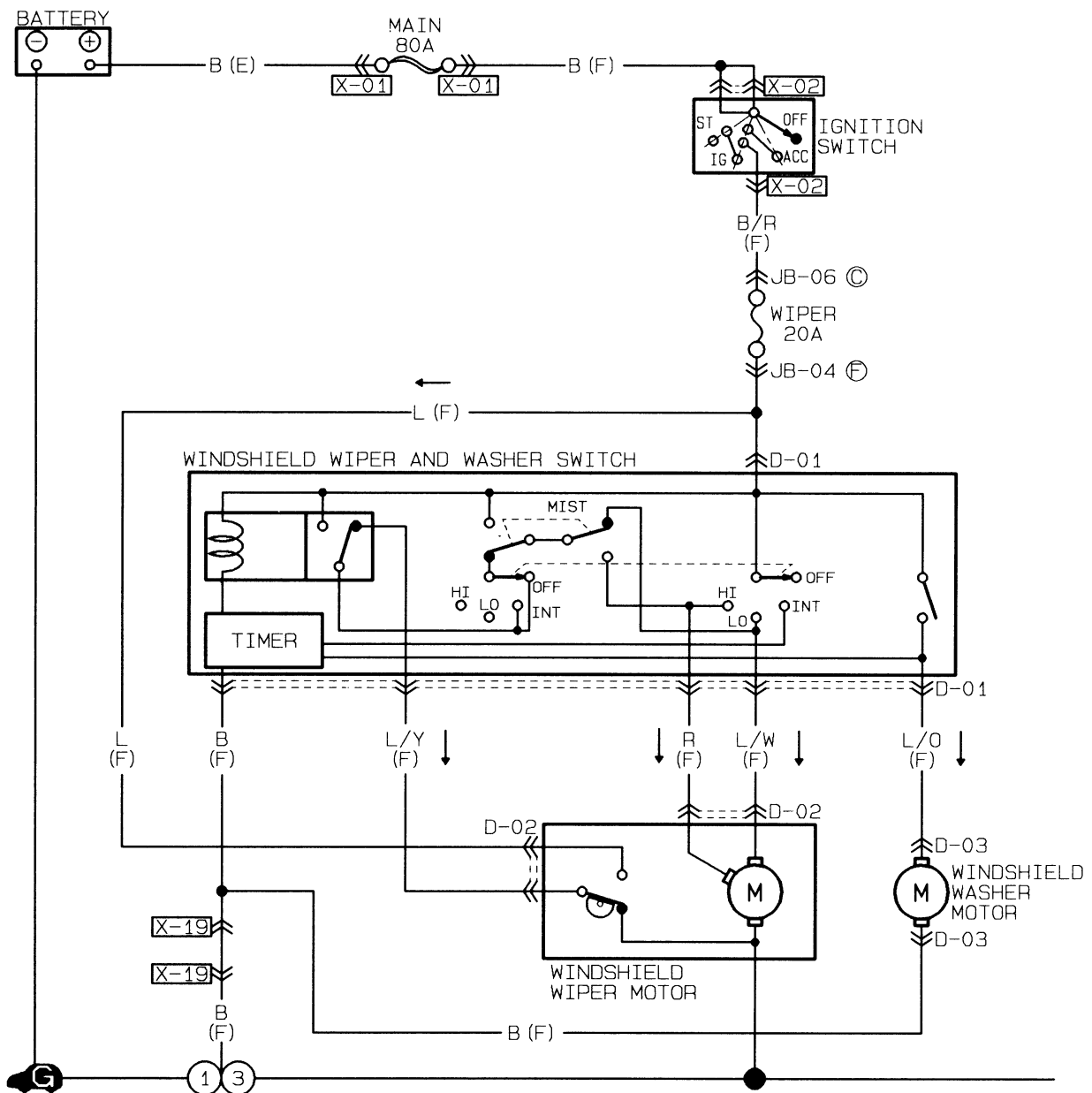

4. The Wipers will not work in the low speed position. All other positions function correctly (high speed, intermittent, mist, etc.). Trace in RED the area(s) that could be at fault.
5. The Wipers will not work in any position, however the washer motor works. Trace in BLUE the area(s) that could be at fault.

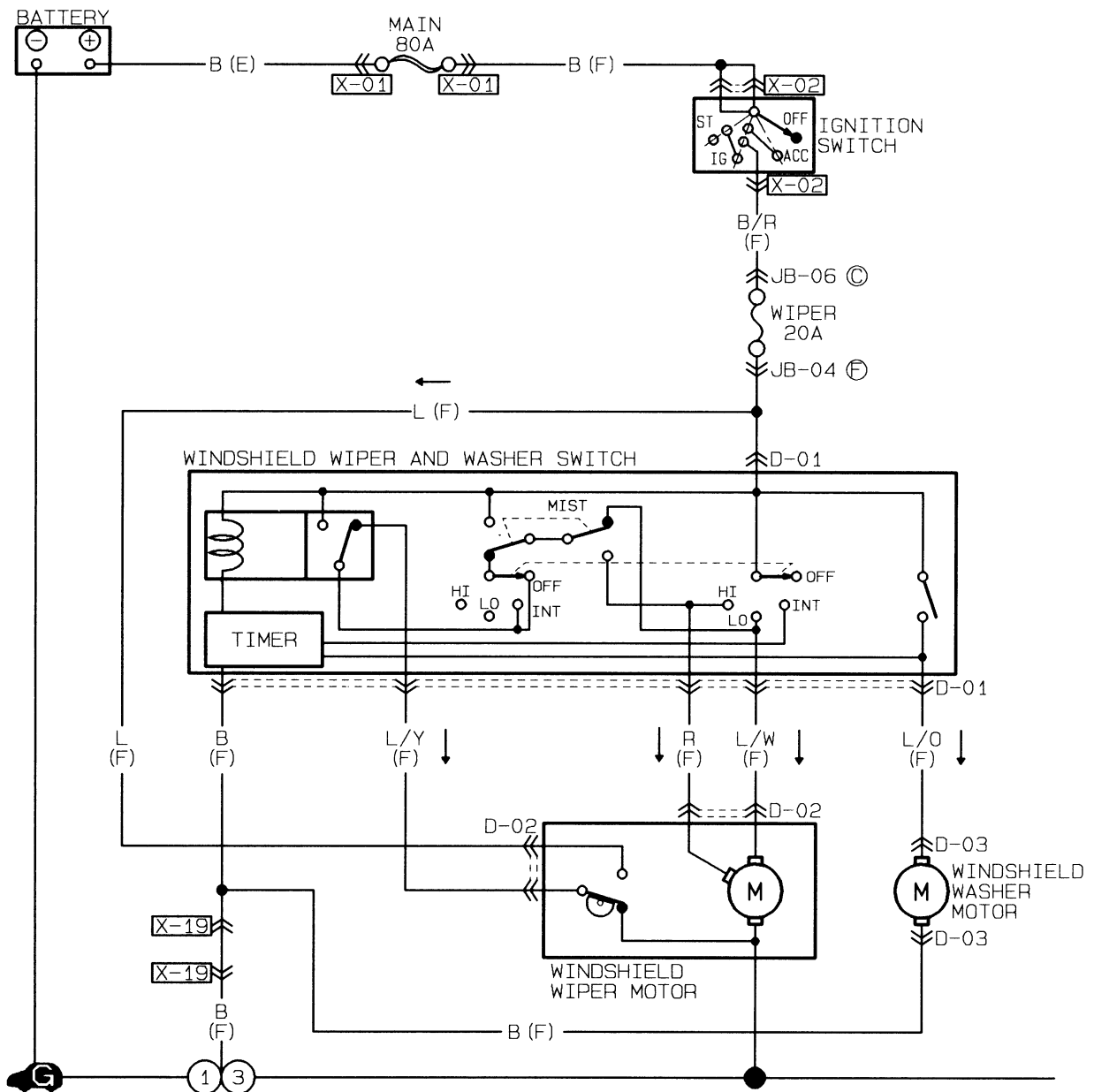

# MAZDA

## Blower Circuits Worksheets

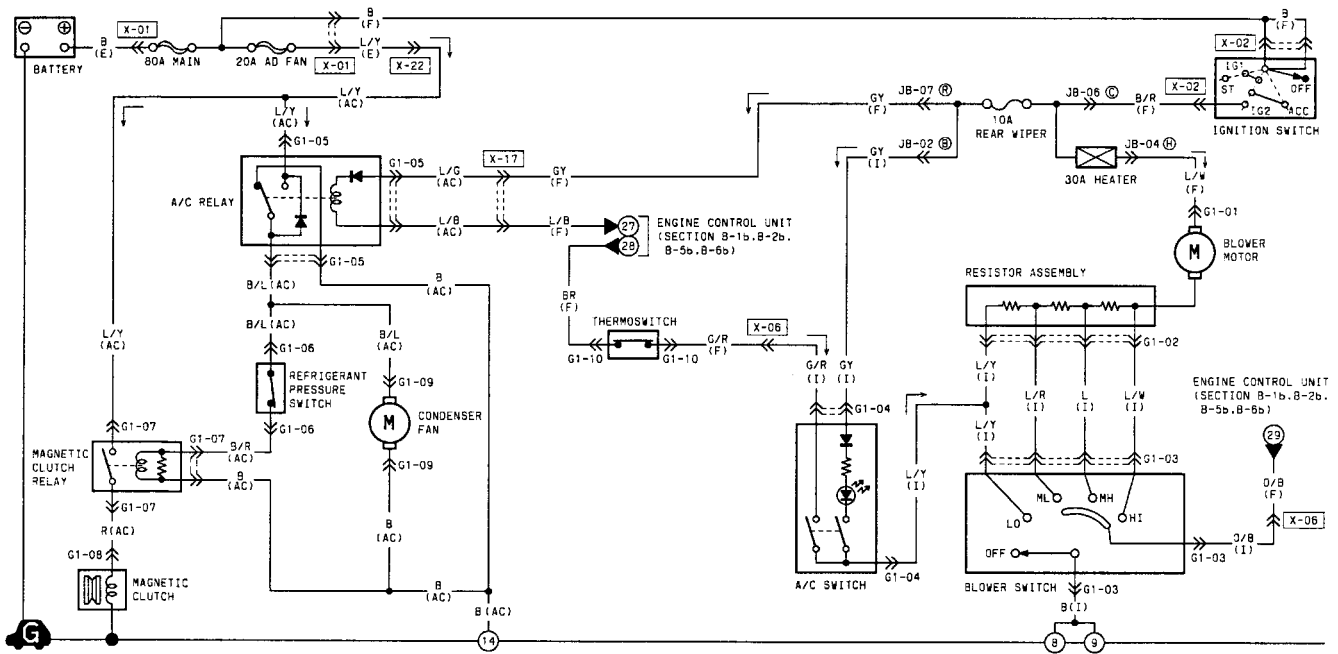

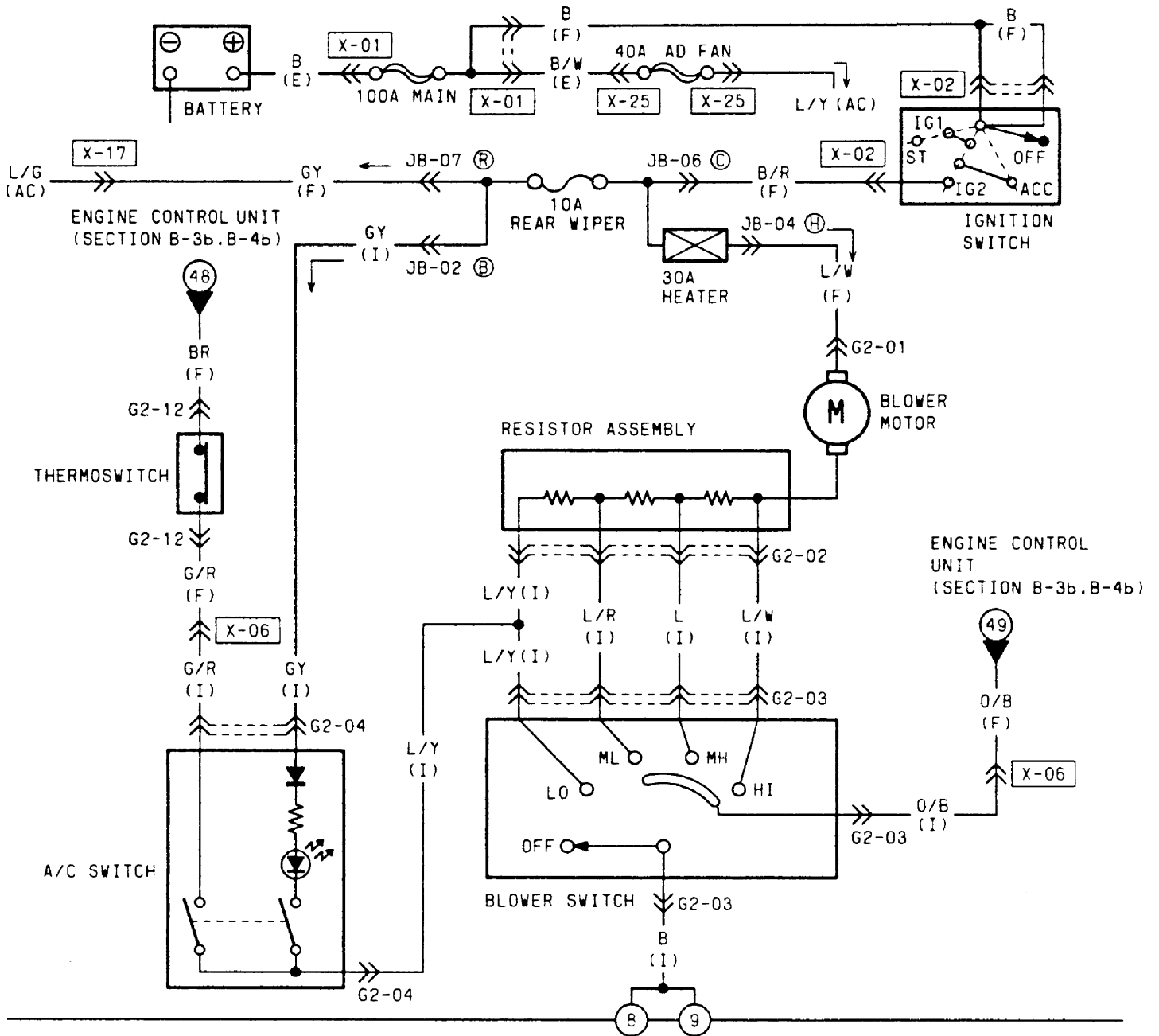

1. Draw in BLUE the BLOWER CIRCUIT with the BLOWER in the LOW SPEED position.
2. Draw in GREEN the BLOWER CIRCUIT with the BLOWER in M1 SPEED position.
3. Draw in ORANGE the BLOWER CIRCUIT with the BLOWER in HIGH SPEED position.
4. Explain the difference between the HI SPEED circuit and ALL OTHER SPEEDS.

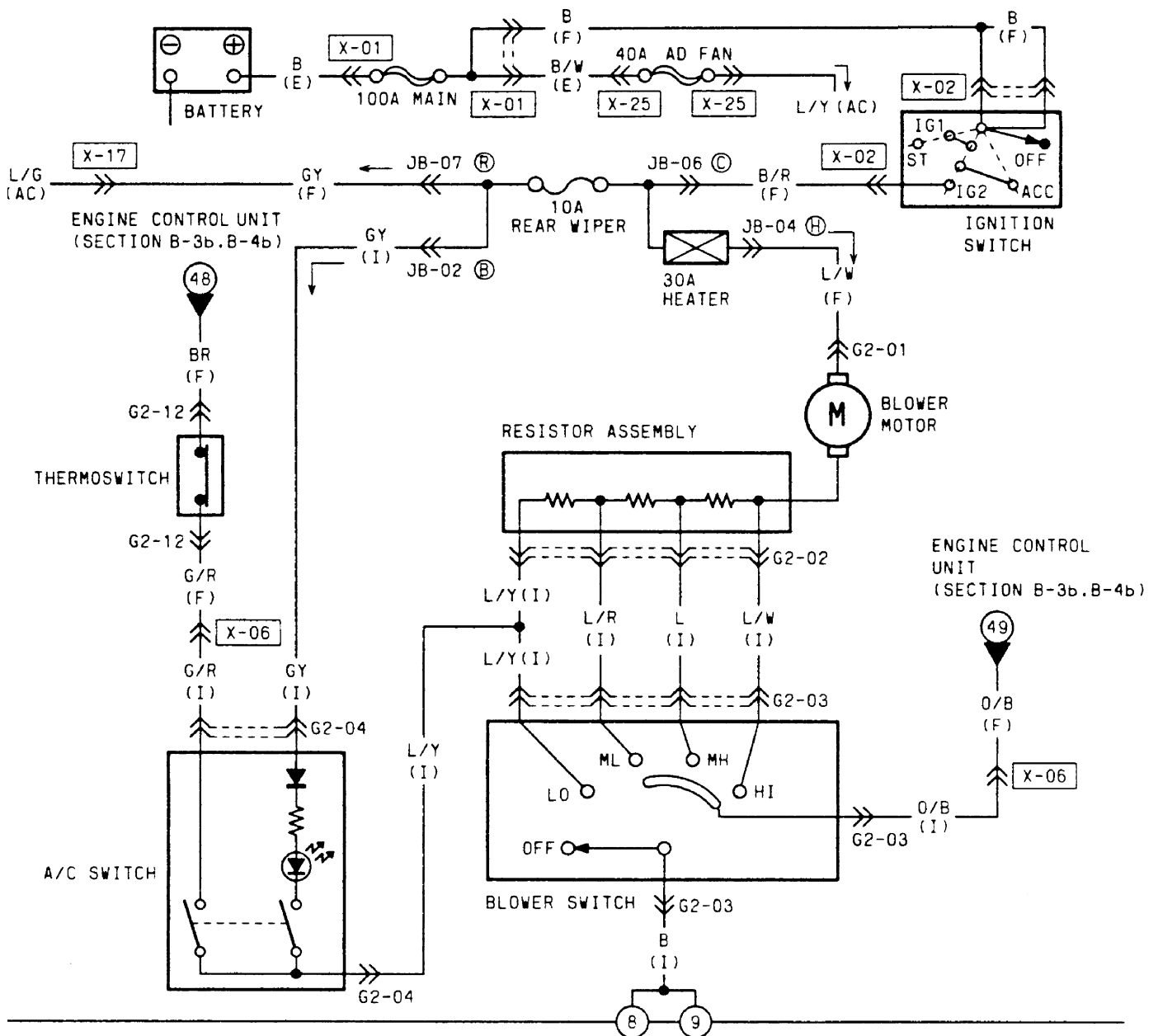

Determine what the affect will be on the following circuit.

1. How will the circuit be affected if there is an open at point **W**.
2. How will the circuit be affected if there is an open at point **X**.
3. How will the circuit be affected if there is an open at point **Y**.
4. How will the circuit be affected if there is an open at point **Z**.

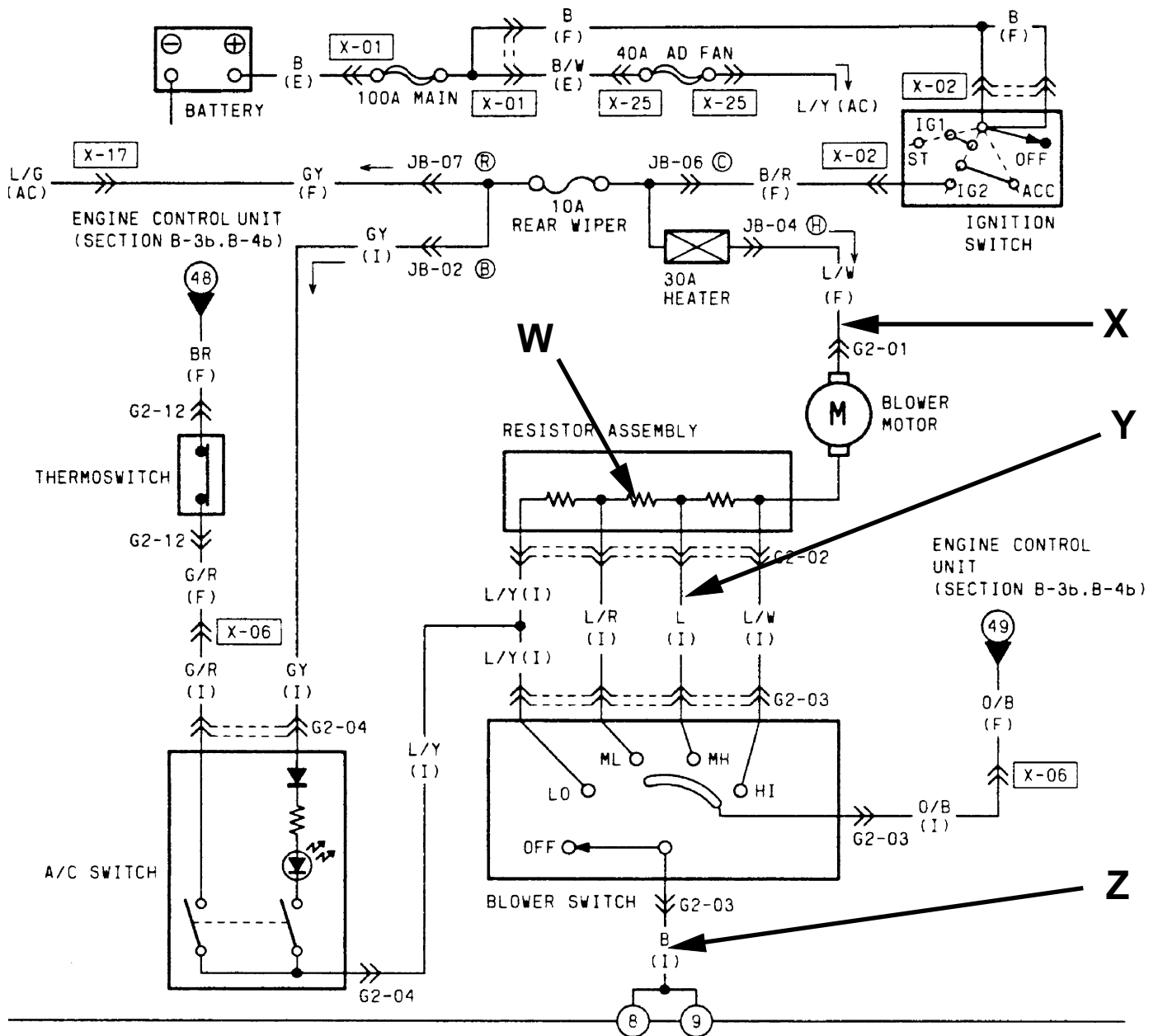

1. The HIGH SPEED blower works but none of the other speeds work.  
Trace in RED the area(s) that could be at fault.
2. The LOW SPEED blower does not work. All other speeds work correctly.  
Trace in BLUE the area(s) that could be at fault.
3. None of the blower speeds work. The A/C switch does light up when pushed.  
Trace in GREEN the area(s) that could be at fault.
4. The ML (medium Low) speed does not work. All other speeds function correctly..  
Trace in ORANGE the area(s) that could be at fault.

